

pgk

LAMS-2698 Revised

CIC-14 REPORT COLLECTION  
**REPRODUCTION  
COPY**

**C.3**

**LOS ALAMOS SCIENTIFIC LABORATORY  
OF THE UNIVERSITY OF CALIFORNIA ○ LOS ALAMOS NEW MEXICO**

---

HAZARDS EVALUATION FOR THE LOS ALAMOS  
CRITICAL ASSEMBLY FACILITY

LOS ALAMOS NATIONAL LABORATORY  
3 9338 00371 1230

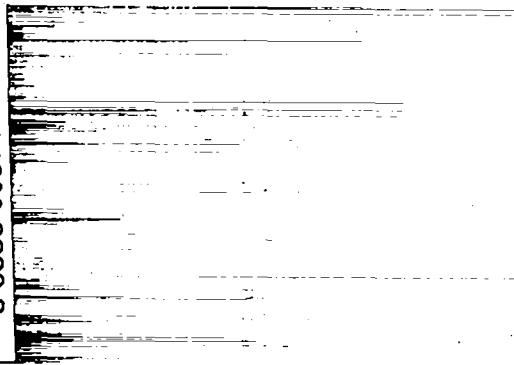

## LEGAL NOTICE

This report was prepared as an account of Government sponsored work. Neither the United States, nor the Commission, nor any person acting on behalf of the Commission:

A. Makes any warranty or representation, expressed or implied, with respect to the accuracy, completeness, or usefulness of the information contained in this report, or that the use of any information, apparatus, method, or process disclosed in this report may not infringe privately owned rights; or

B. Assumes any liabilities with respect to the use of, or for damages resulting from the use of any information, apparatus, method, or process disclosed in this report.

As used in the above, "person acting on behalf of the Commission" includes any employee or contractor of the Commission, or employee of such contractor, to the extent that such employee or contractor of the Commission, or employee of such contractor prepares, disseminates, or provides access to, any information pursuant to his employment or contract with the Commission, or his employment with such contractor.

Printed in USA. Price \$ 2.00. Available from the  
Office of Technical Services  
U. S. Department of Commerce  
Washington 25, D. C.

LAMS-2698 Revised  
CRITICALITY STUDIES  
TID-4500 (18th Ed.)

**LOS ALAMOS SCIENTIFIC LABORATORY**  
**OF THE UNIVERSITY OF CALIFORNIA LOS ALAMOS NEW MEXICO**

**REPORT WRITTEN:** April 1962

**REPORT DISTRIBUTED:** November 6, 1962

**HAZARDS EVALUATION FOR THE LOS ALAMOS**  
**CRITICAL ASSEMBLY FACILITY**

by

W. U. Geer  
P. G. Koontz  
J. D. Orndoff  
H. C. Paxton

**Contract W-7405-ENG. 36 with the U. S. Atomic Energy Commission**



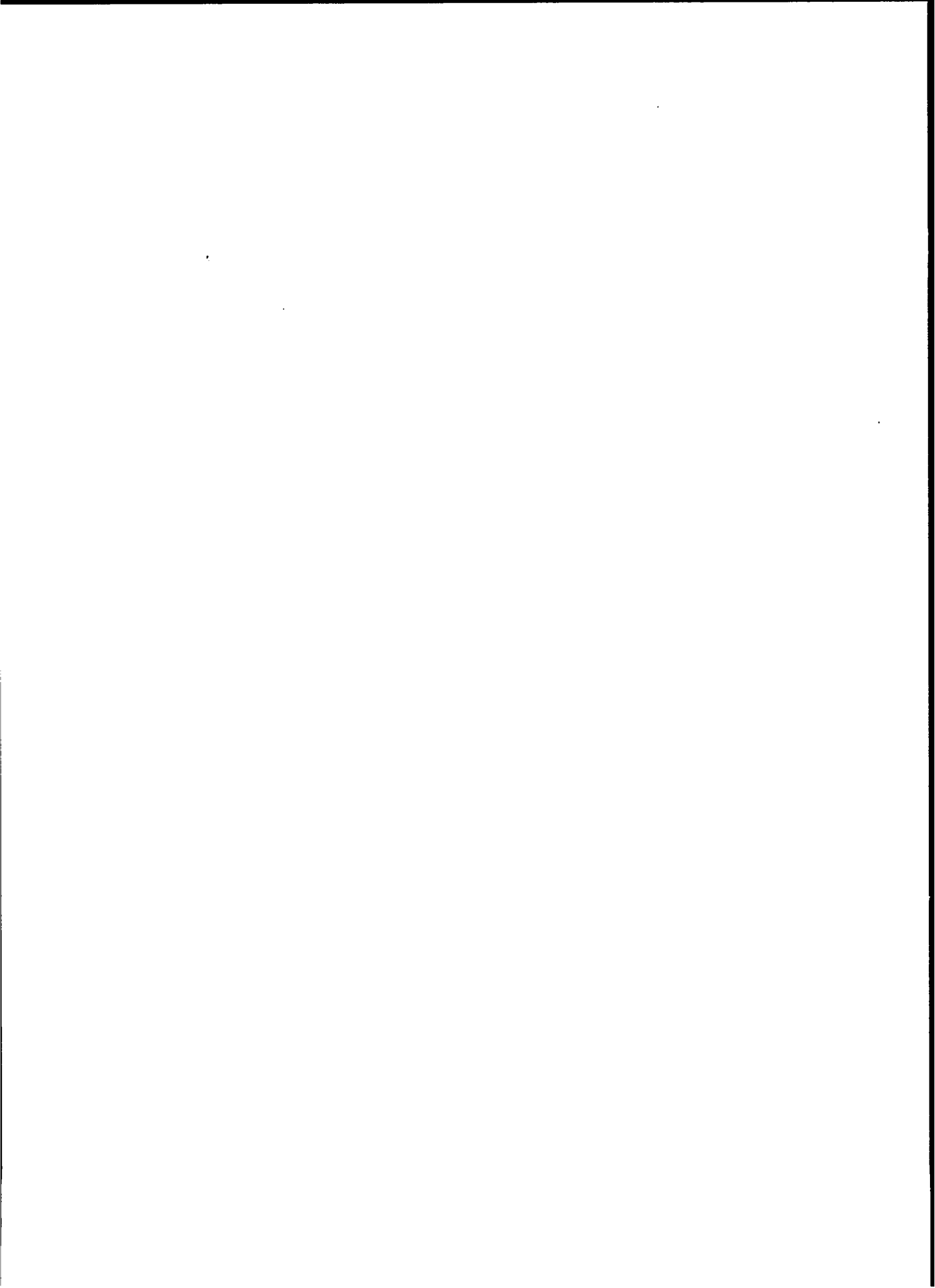

## ABSTRACT

The safety of Pajarito critical assembly operations depends upon remote control and upon good practice as defined by operating regulations and experimental plans. Distance, in some cases supplemented by shielding, would protect personnel against an extreme accident generating  $10^{19}$  fissions.



## Background

The Los Alamos critical assembly facility now consists of three independent assembly buildings (called "Kivas") which are operated remotely from three separate but grouped control rooms 1/4 mile from two Kivas (Nos. 1 and 2) and somewhat closer to the third. Kiva No. 1 was first used in 1947. Shortly thereafter, a universal machine called "Topsy" was constructed to investigate enriched uranium metal cores in a thick normal uranium reflector. Later this machine was adapted to a nickel reflector and other cores. As the weapon program expanded and weapon design became more sophisticated, the critical assemblies group was called on to make measurements to: 1) aid in the design of experimental nuclear explosive devices, 2) establish nuclearly safe procedures for handling, storing, and transporting weapons, and 3) provide neutron physics parameters necessary for the calculation of weapons systems. The work load soon became more than could be handled by one assembly building

and Kiva No. 2 was constructed in 1950 along with the present main laboratory building where the control rooms are located.

Effort continued to be categorized as above with direct weapon work of prime concern. Weapons were designed so close to limits that detailed experiments were required to certify that all phases of loading and handling were safe. The nuclear safety category was expanded to include safety of active material processing and fabrication operations both locally and AEC-wide. The reactor physics research program was broadened to include basic information on fissile and nonfissile materials of interest to weapon and reactor development, particularly in the derivation of consistent parameters for use in multigroup machine calculations.

In 1955 the Rover reactor category was added and has become a dominant field although weapon and nuclear safety responsibilities and other reactor interests are still active. Demands of the Rover program led to construction of Kiva 3, in which preliminary assembly studies commenced during February 1961.

Critical assembly machines are frequently relocated to improve operating efficiency when program emphasis is changed.



## Description of Facility

### Location

The Los Alamos critical facility is located at TA-18 (Pajarito Site), which is about two miles from the nearest residential area, and about four-tenths mile from the closest technical area (see Figure 1). It is in a normally arid canyon, and some natural shielding is afforded by surrounding canyon walls (Figures 2 and 3).

### General Features of Kivas

The Kivas are of reinforced concrete and masonry block construction. Each has a traveling crane in the main assembly room. Gas-fired furnaces are used for heating and forced-draft ventilation is provided. Each has provision for storage of active material in a separately locked area, with storage divisions calculated to be nuclearly safe by a factor of two when completely flooded. All outside doors (except to furnace rooms) lock with a key which has limited distribution.

In accordance with operating procedures, a system of five separate radiation level detectors is permanently installed and serves the roles of scram actuators and operational instrumentation. Compressed air is furnished from a common source. Hydraulic supplies are tailored to individual needs.

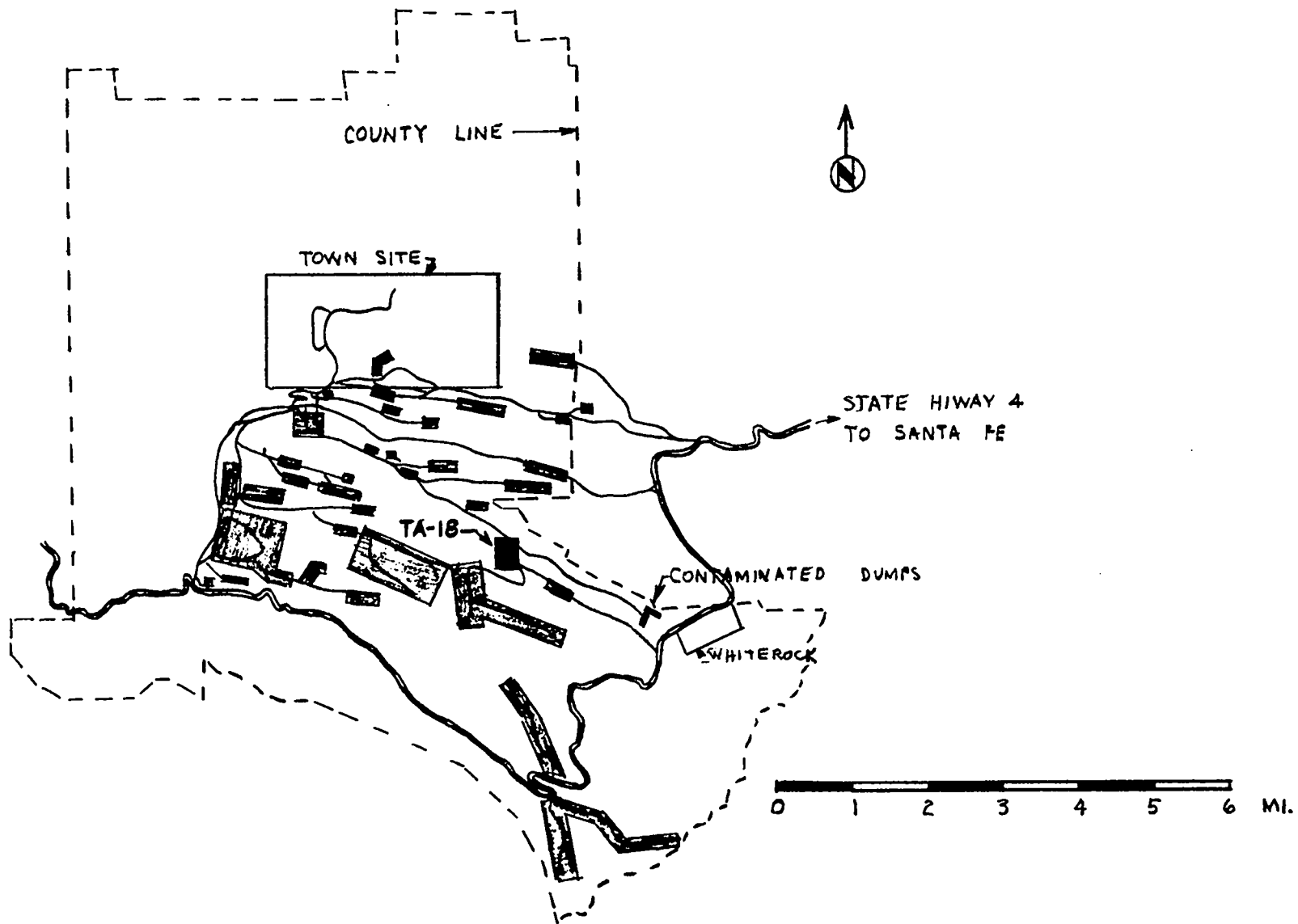

Figure 1. Technical area locations

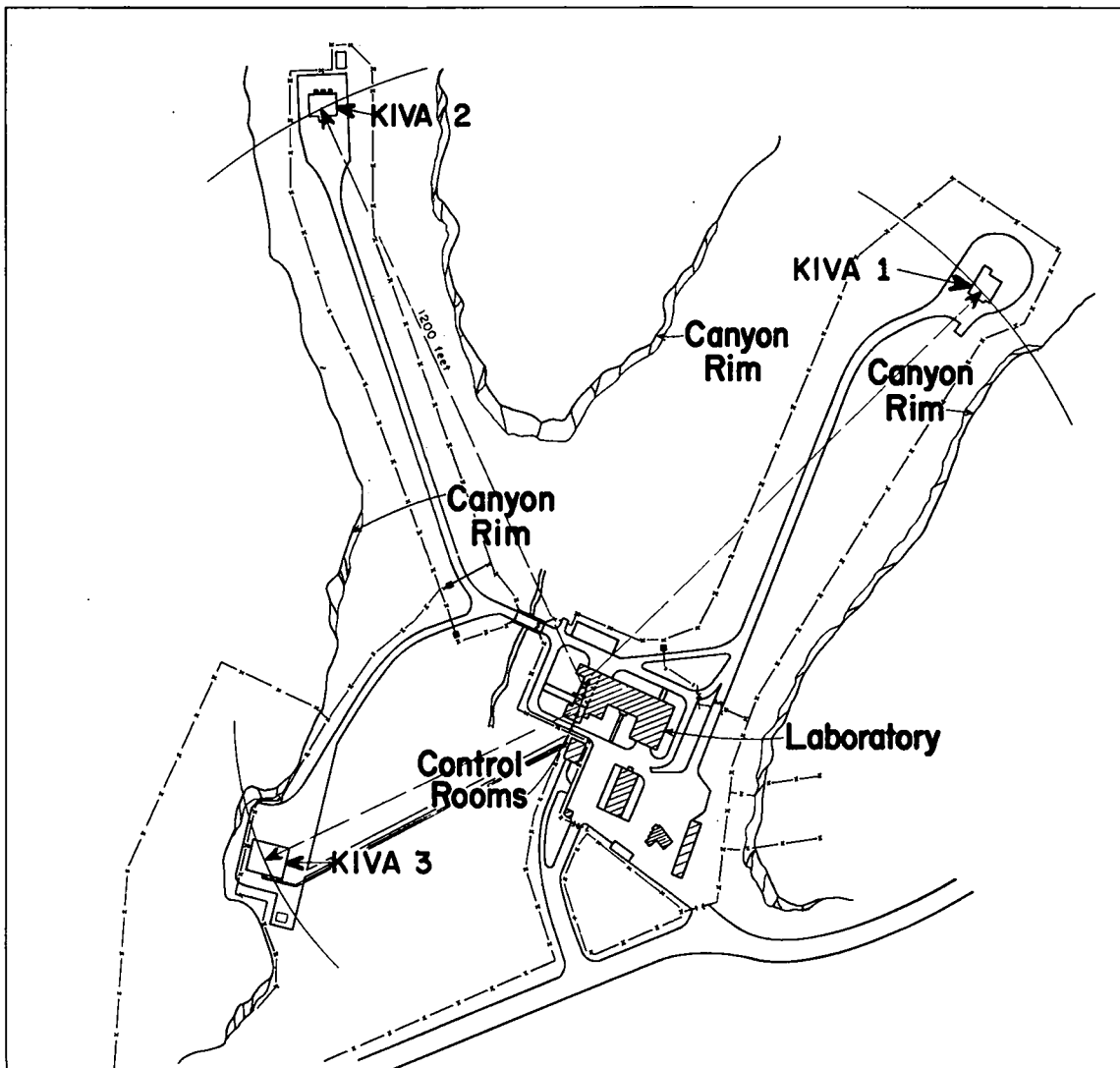

Figure 2. Kiva locations and terrain

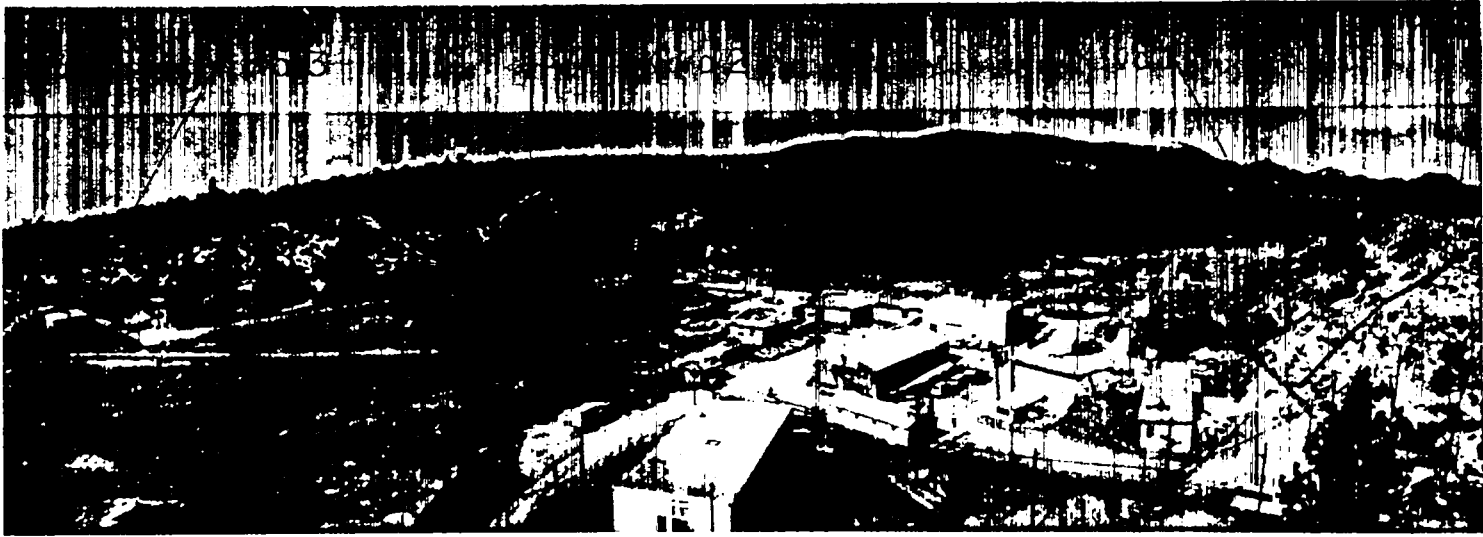

Figure 3. Panorama of Pajarito Site

All major nuclear assembly operations, such as the bringing together of the halves of Honeycomb, are designed to be fail-safe. Thus with the loss of electric power, the assembly reverts to a safe, far subcritical condition.

#### Typical Critical Assemblies

##### Kiva 1 (Figure 4)

In practice, machines in this Kiva run at "zero power"--perhaps 100 watts maximum. The building itself affords only light shielding. Distance of about 1000 feet to the nearest occupied building is a primary safety feature.

Critical assembly machines in Kiva 1 are:

1. Honeycomb: (Figure 5) Honeycomb is a versatile machine for mocking up relatively large critical systems and provides when assembled a 6 ft. cubic matrix of 3" x 3" x 6' aluminum tubes for supporting reactor materials. It is being used presently for mockups of Rover reactors. Scrams retract about one-half of the assembly and withdraw safety rods generally worth ~2\$.

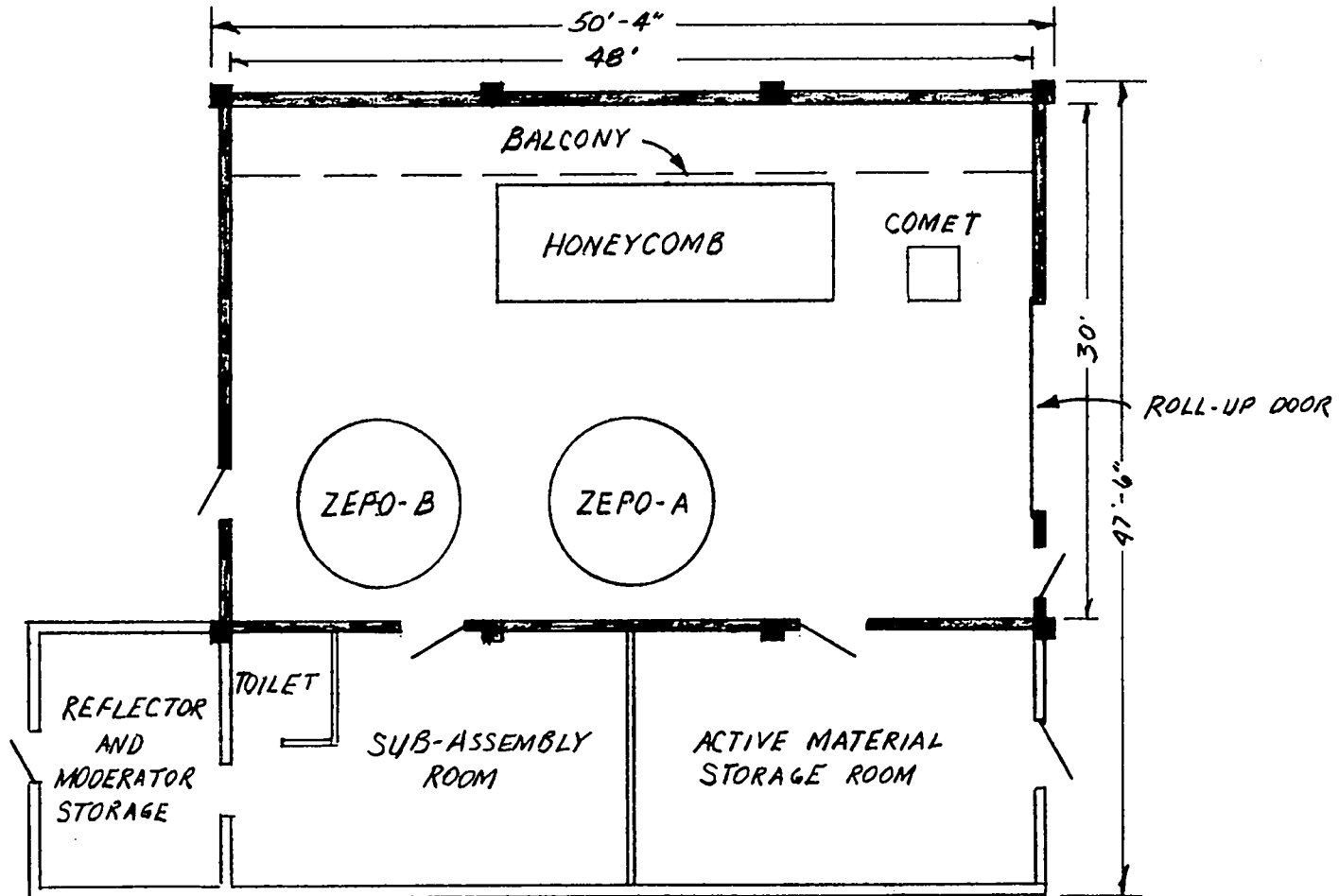

Figure 4. Kiva 1 floor plan

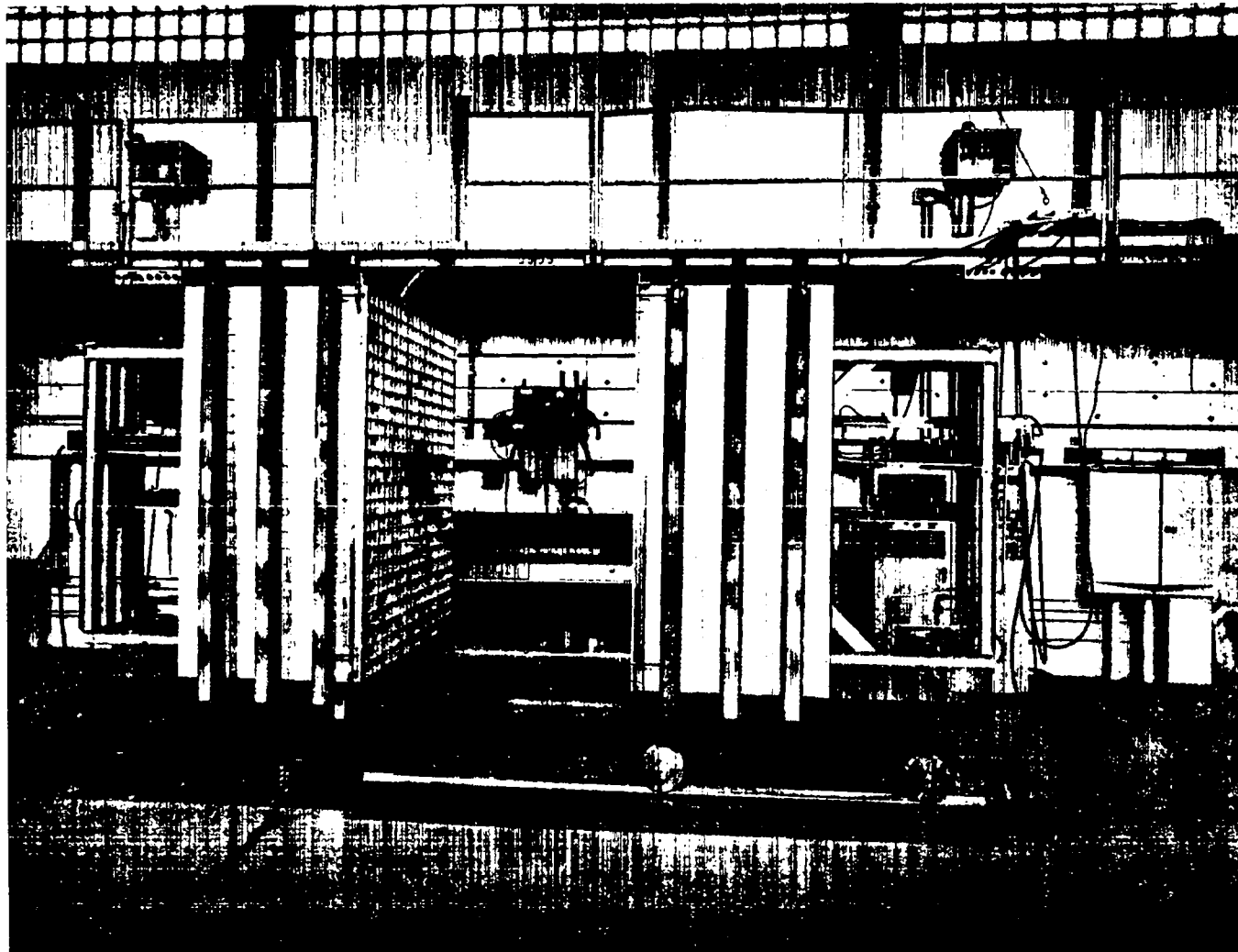

Figure 5. Honeycomb assembly in Kiva 1

2. Zepo B: This is the zero power, nuclearly precise, mockup of Kiwi-B. Originally designed to simulate Kiwi-I, then adapted to Dumbo, it will accommodate other mockups of the Kiwi-B series and Phoebus. A scram signal drops the core out of the reflector and inserts boral sheets into the reflector. The boral alone is worth 1.20\$.

3. Mars: Constructed for mockups of the Kiwi-A reactor, this machine is being adapted to U-graphite systems diluted by hydrogenous materials and Be. Scrams drop one portion of the assembly and raise another part.

4. Comet: (Figure 6) Comet is a simple assembly machine for a variety of tests including "quick and dirty" reactivity checks frequently required for the weapons program. Comet is presently in use in the determination of critical conditions for Pu cylinders diluted with various other metals. As with Planet, the primary scram drops the portion of the assembly carried on the lift.



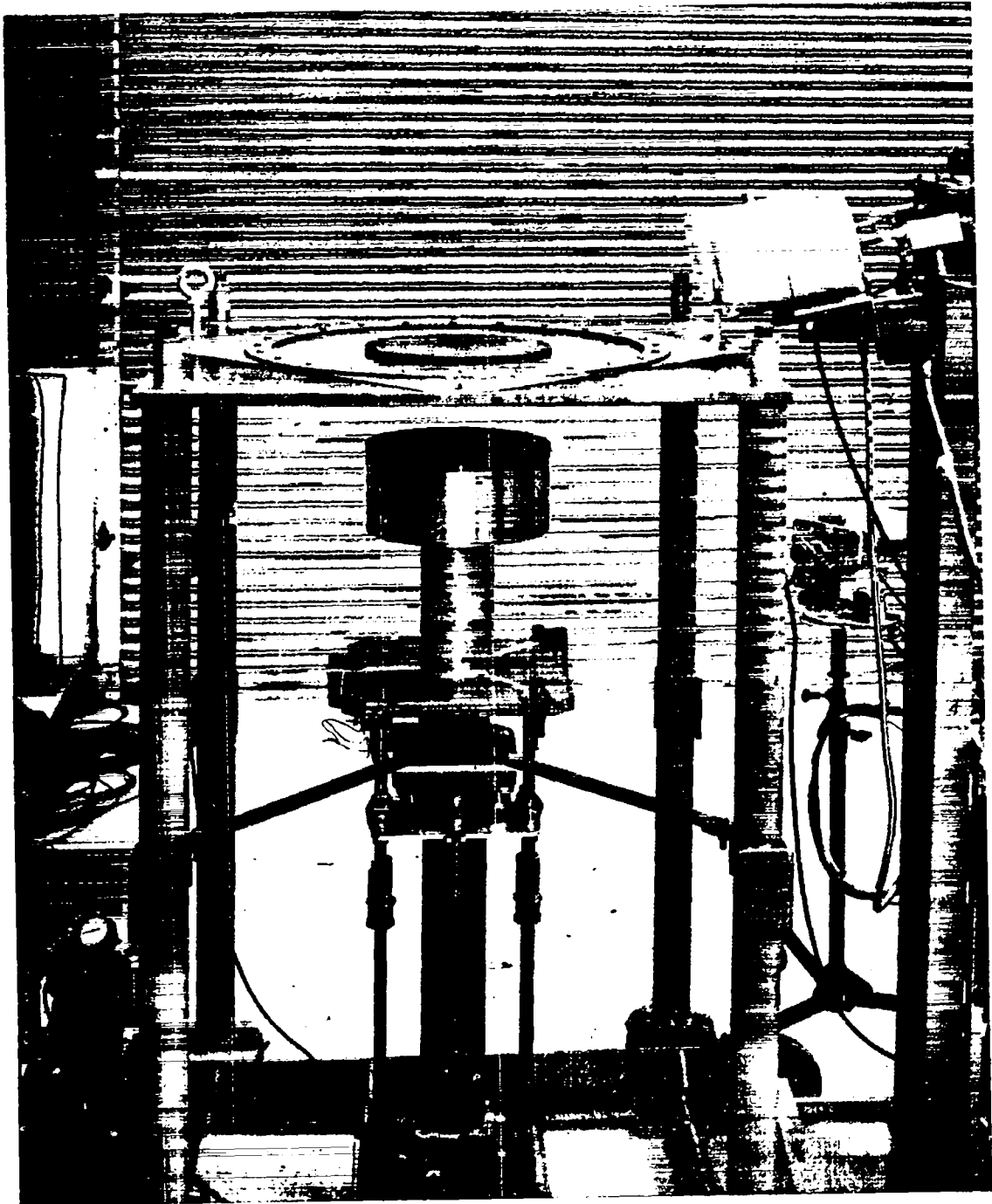

Figure 6. Comet

## Kiva 2 (Figure 7)

At present the main difference from Kiva 1 is that Hydro, located outside the building adjacent to the Kiva is run at about 5 kilowatts power for periods like one hour. (This is usually done during off-hours to minimize exposure of personnel.) The 1100 feet to the nearest occupied building is its primary safety feature.

Critical assembly machines in Kiva 2 are:

1. Jezebel<sup>(1)</sup>: (Figure 8) Jezebel is the unreflected,  $U^{233}$  metal, spherical assembly used for reactor physics investigations. The original Pu components are available for remounting when the  $U^{233}$  program is completed. An essentially portable machine, Jezebel was first installed in Kiva 1. The scram action is separation of the sphere into three nearly equal portions.
2. Flat Top: (Figure 9) Flat Top is a thick normal-uranium-reflected assembly with a choice of Oy,  $U^{233}$ , or Pu metal cores. It is used for fundamental reactor physics studies. Scrams retract two quadrants of the thick reflector.
3. Cavity Assembly: (Figure 10) The Cavity Reactor is a one meter diameter by one meter long cylindrical cavity surrounded by one-half

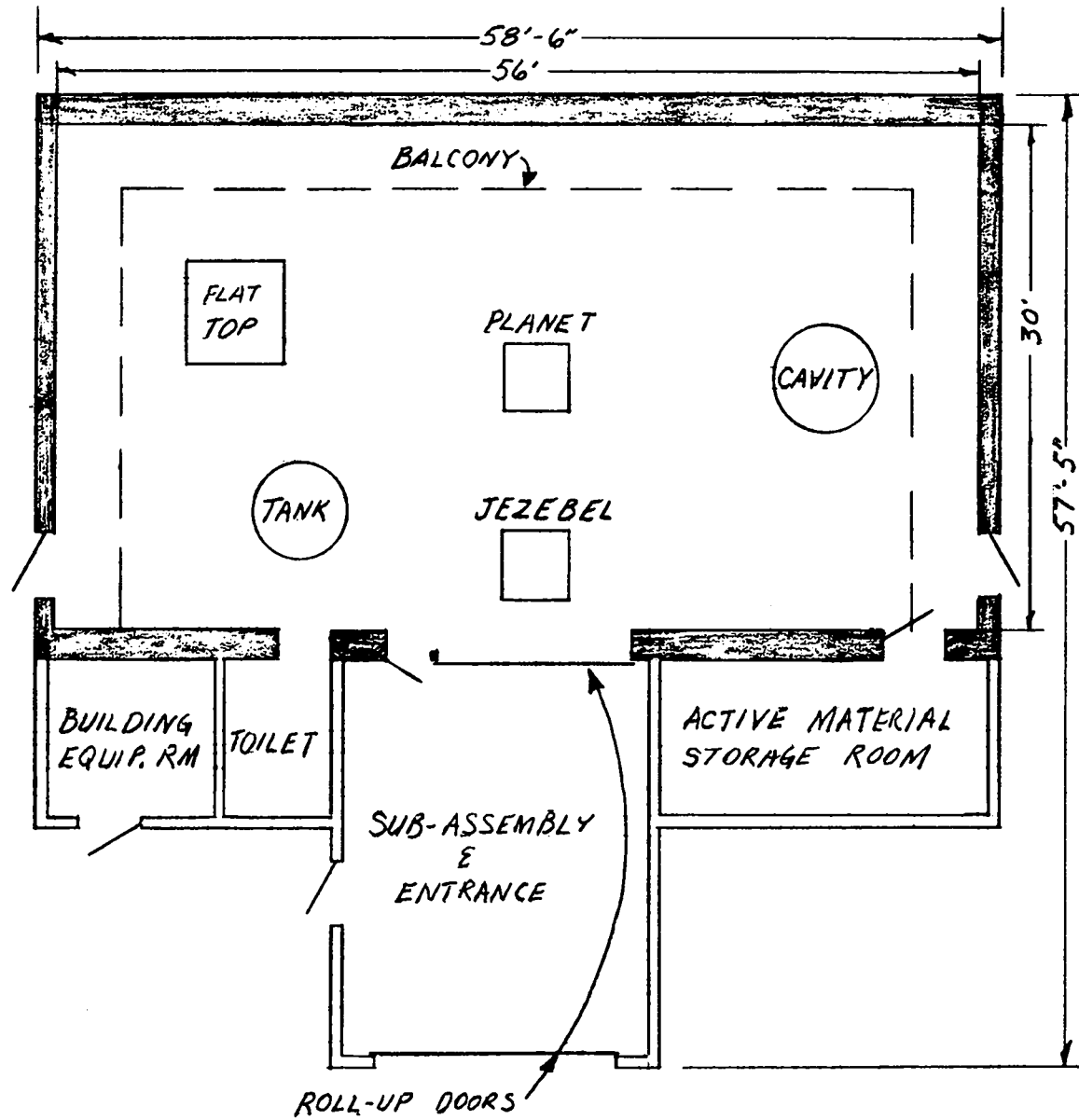

17

Figure 7. Kiva 2 floor plan

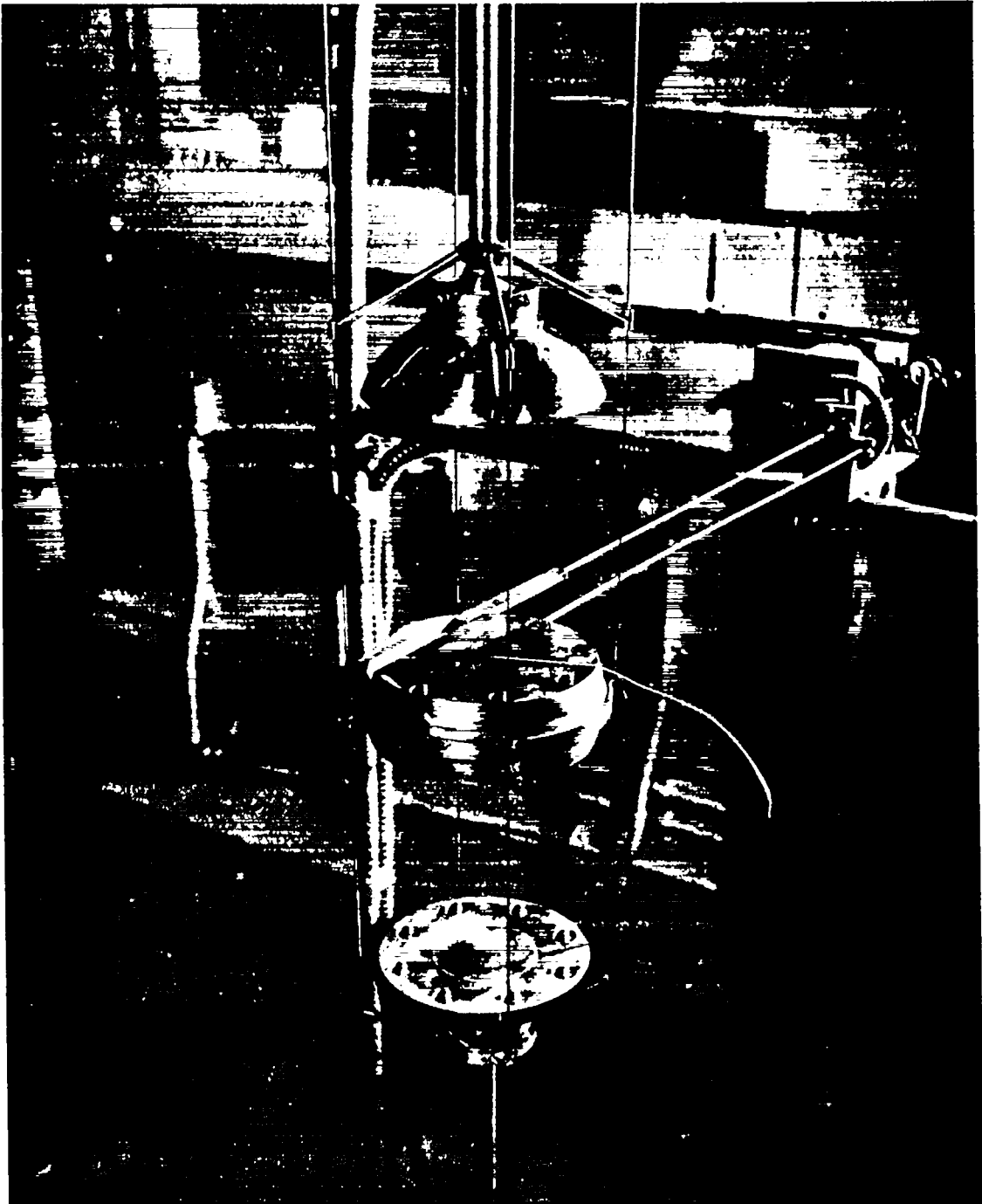

Figure 8. Jezebel in Kiva 2



Figure 9. Flat top

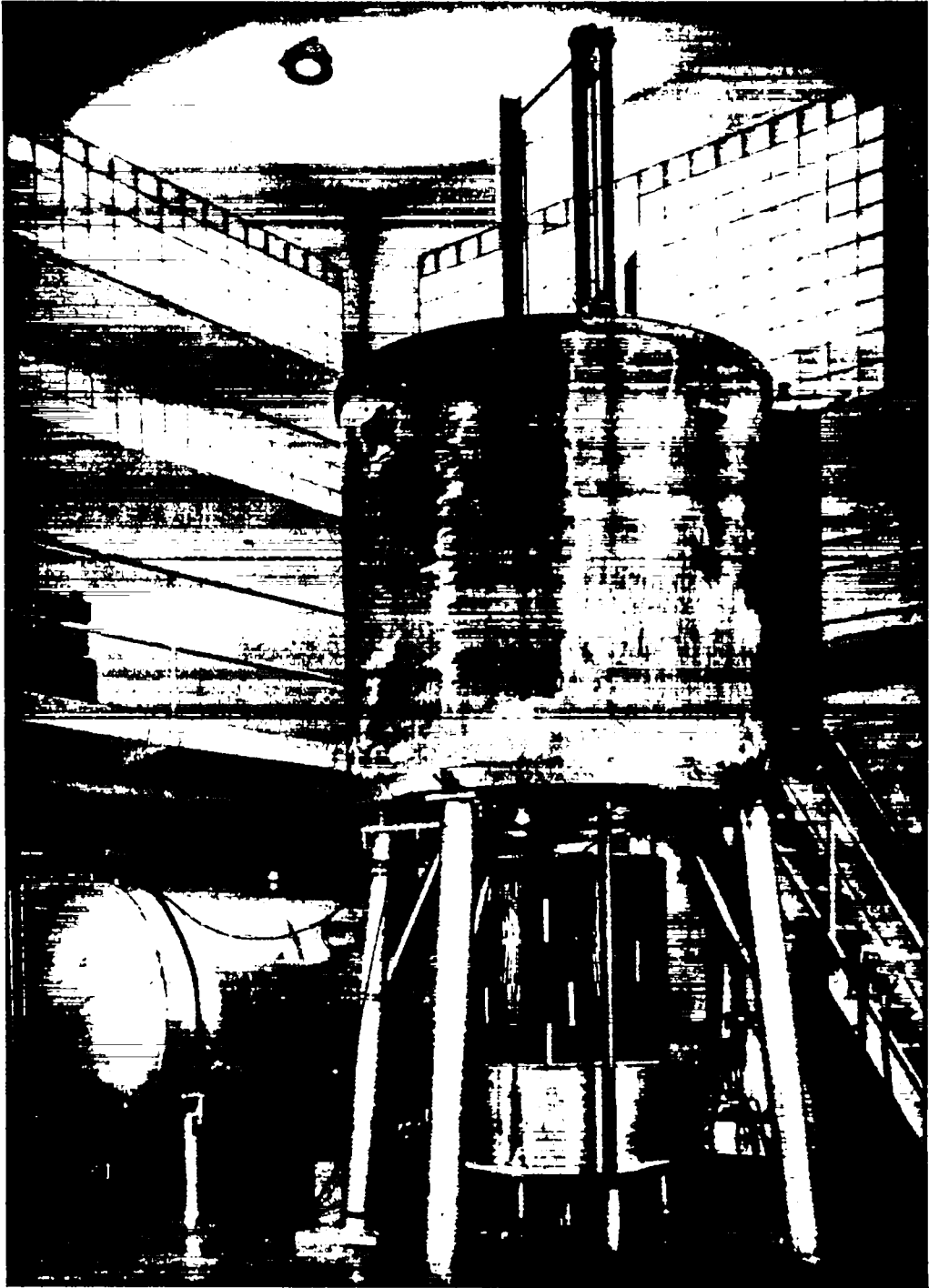

Figure 10. Cavity assembly

meter thick  $D_2O$ . Loading for the unperturbed system is a few mils of enriched uranium foil lining the cavity. The assembly is used for reactor physics studies, and investigating possible Rover or test reactor applications. A scram signal drops the lower reflector plug and core, introduces a 3% Cd rod into the reflector, and initiates draining of  $D_2O$  from the annular reflector tank.

4. Hydro: (Figure 11) Hydro is an enriched uranium metal core assembly cooled and partially reflected with water, capable of operation up to ~5 KW. It is set up outside Kiva 2 and is used as a neutron source for a thermal column or for detector studies. Formerly it drove a uranium exponential column. For scrams, the assembly drops from its upper reflector, the polyethylene control block (0.3%) retracts, and the lateral water reflector drains.

5. Tank: This assembly consists of a tank 70" diameter by 54" high for use in checking nuclear safety of single or multiple units when flooded. This facility is required pri-

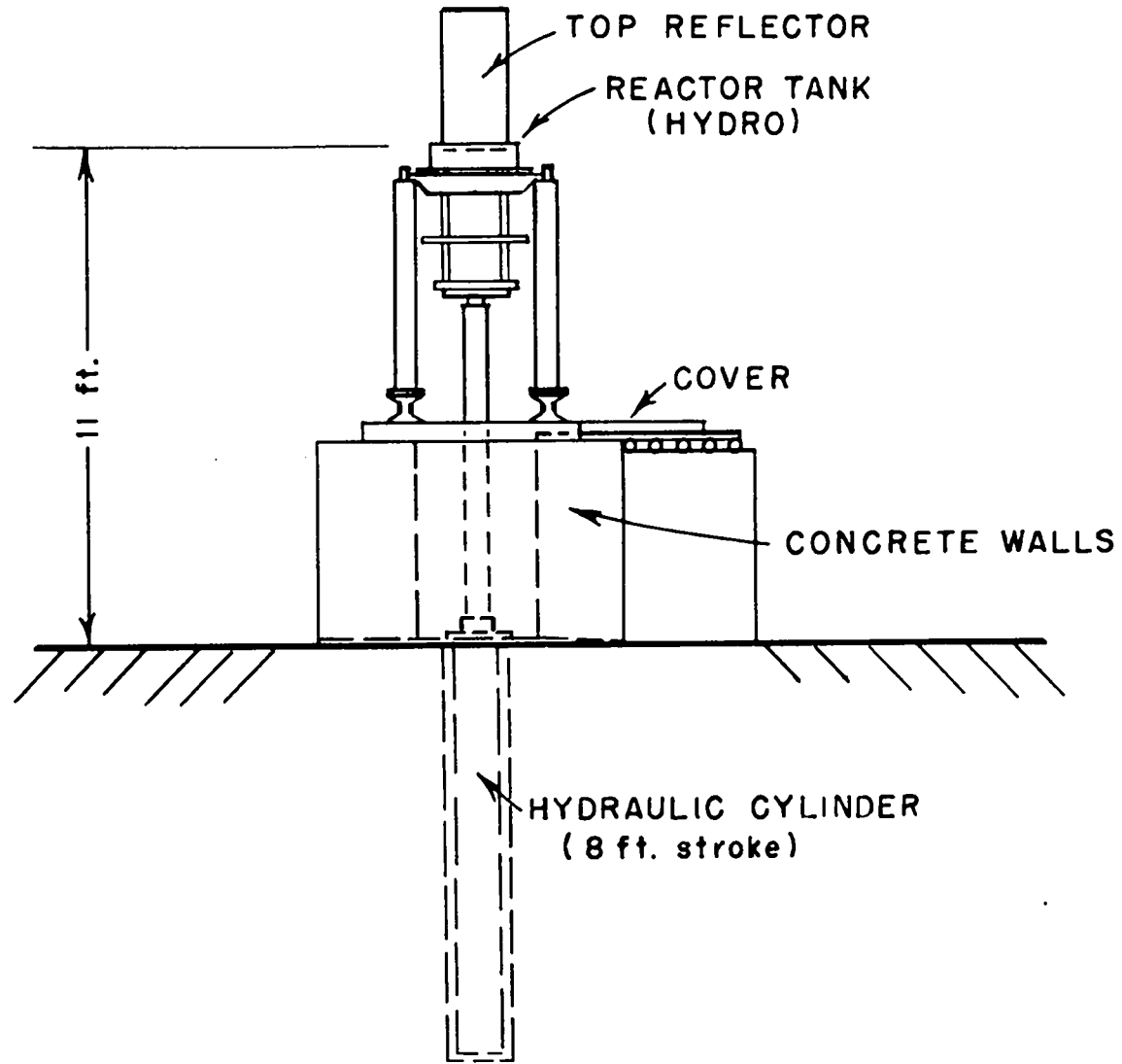

Figure 11. Hydro in outdoor facility



marily for tests of weapon components. The primary scram drains the tank.

6. Planet: The Planet assembly machine is a duplicate of Comet in Kiva 1. For the "Thor" assembly (Pu in thick Th) on this machine, the primary scram dropped a reflector cylinder carrying about 1/3 of the core and a secondary scram raised part of the reflector.

### Kiva 3 (Figure 12)

This is the only Kiva with self shielding, having 18 inch thick walls and ceiling. Distance to the nearest occupied building is 560 feet. Construction is such that reasonable containment is expected in case of a relatively severe excursion. The one entrance into the main room is designed as a tunnel so that radiation scattering to the outside will be minimized, and orientation is such that it points away from the most frequently occupied areas.

The environmental chamber, designed to cool to  $-85^{\circ}\text{F}$  and heat to  $700^{\circ}\text{F}$ , is a major feature of this building. (Temperature is the only controlled parameter.) Its purpose is to subject critical assemblies to other than ambient temperatures, at which most previous experiments have been done. No interaction (other than sluggish temperature control) is expected

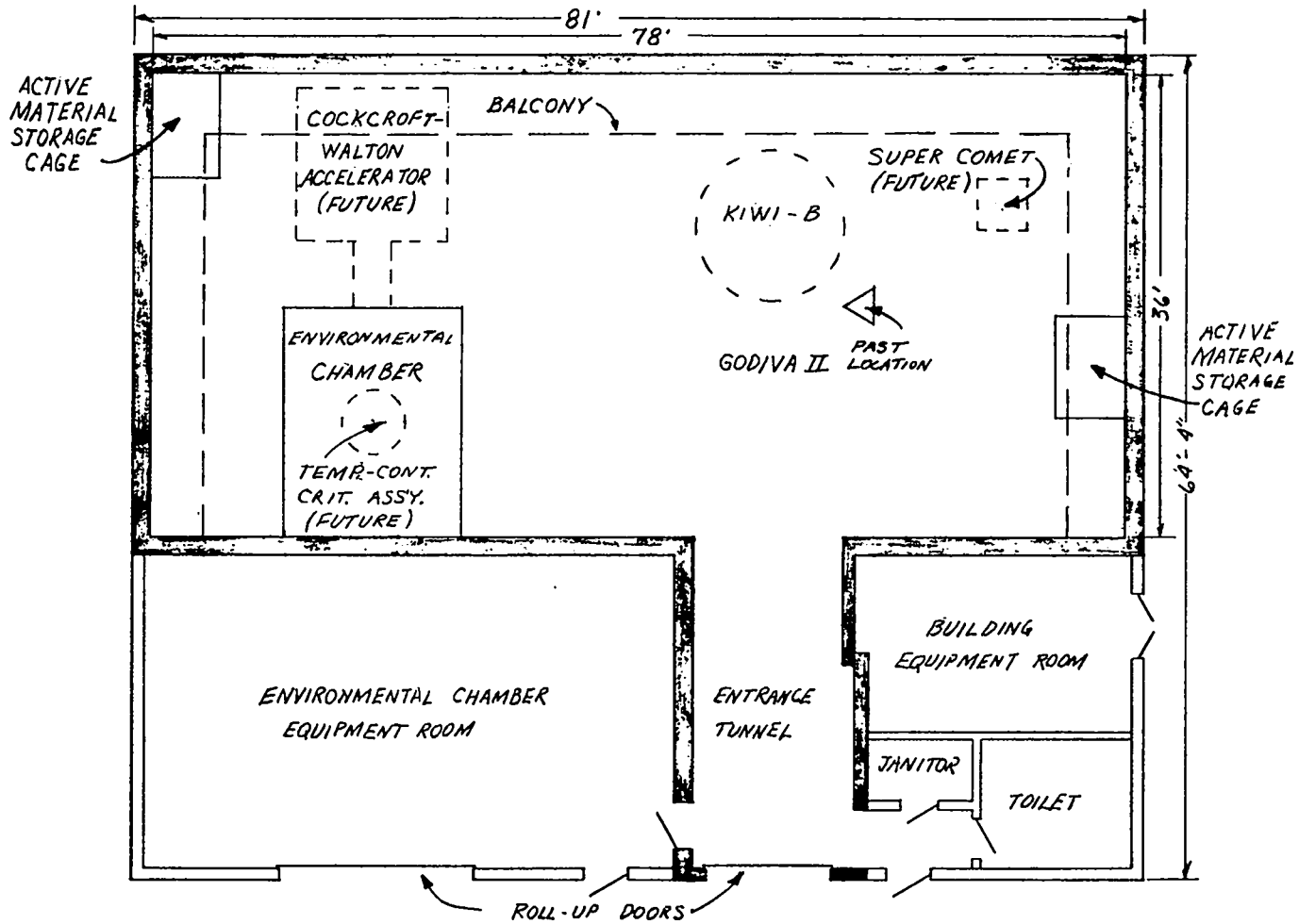

Figure 12. Kiva 3 floor plan

with controls or other features of contained assemblies. The planned temperature range is sufficient to provide information that is sensitive to neutron temperature models without being so extreme as to introduce operational problems. Auxiliary equipment for this is housed in a masonry block section of the building. This chamber is semi-automatic, so that during critical operations, operators will be required only at the control room.

Apart from the temporary operation of Godiva II prior to its retirement, Kiva 3 has been used for preassembly and checkouts of Kiwi-B-1A, Kiwi-B-2A, and Kiwi-B-4. This operation, illustrated by Figure 13, will be duplicated for other Rover test reactors. In addition, "Supercomet," a versatile, heavy duty version of Planet or Comet, will be installed for general critical assembly work.

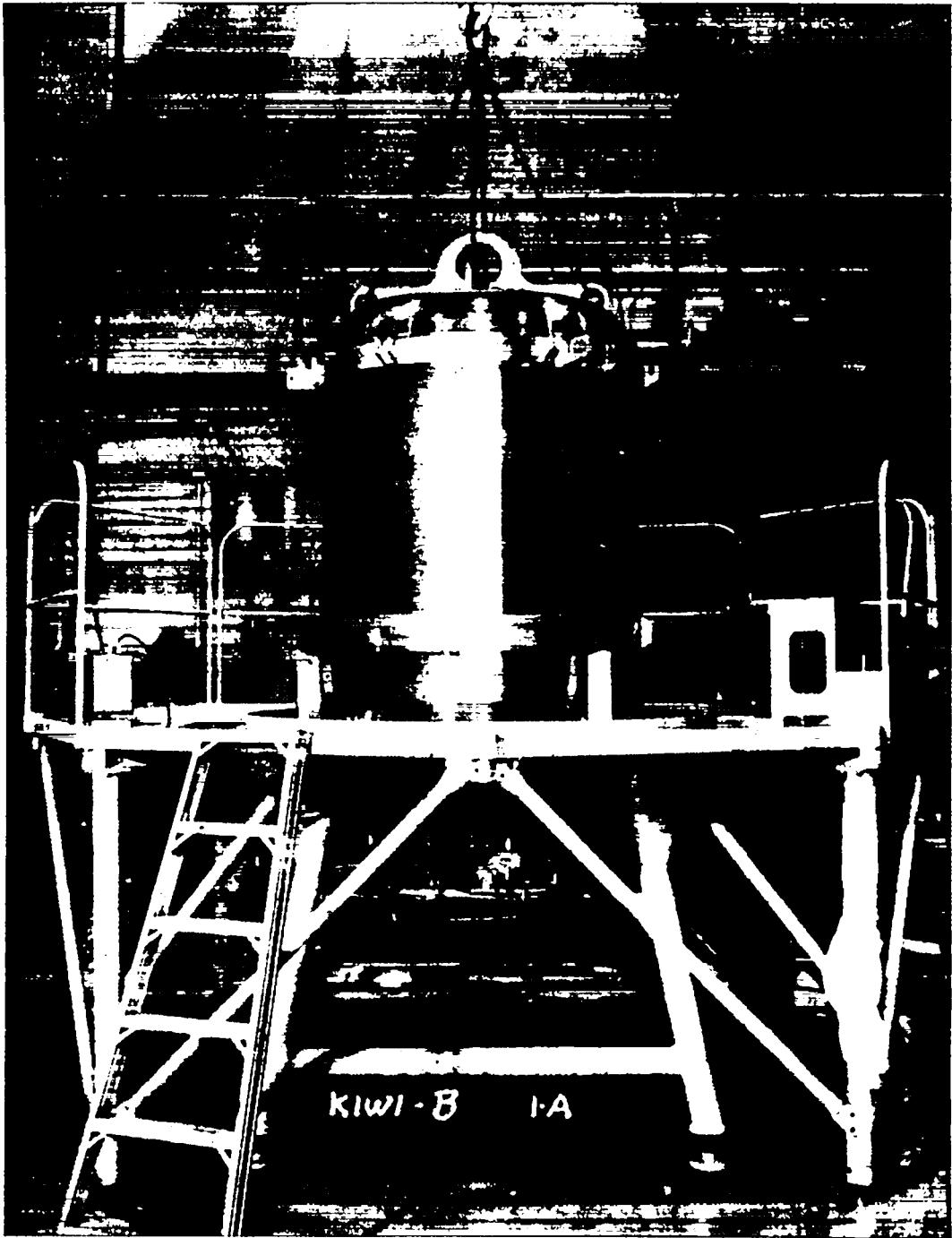

Figure 13. Kiwi-B reactor in Kiva 3

## Description of Experimental Procedures

LASL remotely controlled critical assembly facilities have been operated satisfactorily for nearly twelve years. During this period many hundreds of critical configurations have been established without radiation accidents to personnel. In addition to the influence of favorable facilities and conscientious personnel, this success is partially attributable to operational procedures that have been established, refined, and formalized. Experiments are controlled by a set of comprehensive operating regulations. In addition, each separate experiment must be described by an experimental plan in which any special features, not covered by the general operating regulations, are spelled out. Experimental Plans must be approved by an N-2 Nuclear Safety Committee, the Group Leader, and the Division Leader. Operating Regulations are included below and an illustrative experimental plan is given in the Appendix (page 65ff).

Operating Regulations for the  
Remote Control Laboratories at Pajarito

I-A Introduction

The "Operating Regulations" for experiments with fissile materials by the critical assemblies group at Pajarito have been revised to adapt to changes in program and to incorporate results of nearly fifteen years experience. This new set of rules, which supersedes an informal document, does not represent any major change in basic philosophy or safety criteria, but, in addition to the provision for the storing of active material not installed in a machine, more consideration is given to the different types of machines which have grown out of an expanded and a more varied program.

Although the basic philosophy has been and continues to be that "Regulations alone cannot guarantee safety, but must be supplemented by the vigilance of the individuals performing such experiment," nevertheless, some rules of procedure and limitations of operations are necessary for the safe operation of critical experiments by a group of individuals. It is to be hoped that a set of rules, coupled with the carefulness and vigilance of the individuals, will prevent serious accidents with experiments which, at best, are hazardous. Such rules should not be so stringent that they unduly restrict progress or the investigation of a new idea. As in the

past, it is believed that the control of personnel hazard is of paramount importance, and that, if haste contributes to the hazard, the consideration of safety shall take precedence over that of saving time. It is also the aim of these regulations to protect valuable fission materials and to maintain continuity of operations in the Kiva areas. In rewriting these regulations, many sentences and paragraphs have been taken unmodified from the first set of rules.

#### I-B Facilities and General Practice

These "Operating Regulations" apply to any experiment which is performed at one of the remote control laboratories, known as Kivas, at Pajarito Site. The Kivas, which are located at some distance from the main laboratory building in which the corresponding control rooms are placed, as shown in Figure 2, are surrounded by fences to keep personnel at a safe distance from the Kivas during the remote control operation. All remote controls and indicators, including closed circuit TV receivers, are mounted in the control room.

Access to the Kiva areas is regulated by the Safety Plans 1, 2, and 3 as defined in Section II-A. These areas usually contain active material in addition to that which is directly involved in a particular experiment. Section II-B will treat briefly the general consideration for storage of the active material in the Kivas and the vault.

Certain features of operations with fissile materials in the Kivas have become standard practice. The procedure for each type of experiment is established by an approved Experimental Plan (see Section II-C.1). In all such operations, hand assembly of fissile materials is limited to demonstrably safe units. Where safe limits for hand assembly are to be exceeded, the ultimate reactive configuration is divided into two or more subunits, each safe for hand assembly, and these subunits brought together by means of a remotely controlled machine. If a preselected neutron level is exceeded at any one of two or more neutron safety monitors, the machine is automatically disassembled or "scrammed."

#### I-C Criteria for Regulations

The choice of operating regulations is guided by the following considerations: 1) For personnel protection, the important periods are when a Kiva safety area is accessible, particularly during hand-stacking operations. At such times, it must be guaranteed that the reactivity margin is not only below delayed critical but also is large with respect to such influences as measurement uncertainties and incidental tamping effects. Precautions under these conditions should be the equivalent of those observed in plants for processing and fabricating fissile materials. 2) Obviously, a higher degree of property



risk must be accepted for remote operation (with the Kiva area vacated). During such a period precautions are required to guard against inadvertent entry into the prompt critical region, where a damaging reaction may occur, and against a highly radiating system that cannot be disassembled remotely. These precautions depend upon proper machine characteristics and properly interpreted guiding measurements, instead of the generous safety margin that is provided by ordinary nuclear safety standards.

To convert these general ideas into specific rules, it is necessary to introduce readily measurable numbers that can serve as safety criteria. In the reactivity region below delayed critical, "central source" neutron multiplication<sup>(2, 3)</sup> is the practical primary safety index, with the convenient property that reciprocal multiplication becomes zero at delayed critical. For example, in progressing toward an unknown configuration of active material from one known to be safe, the safety of the stage to be entered is judged by preceding multiplication measurements. Conservative extrapolation of a plot of

reciprocal multiplication against the parameter controlling reactivity (i.e., mass of fissile material, tamper thickness, separation of subunits) establishes safe limits for each increase of reactivity.

For spherical fast neutron systems, a central source multiplication of 10 corresponds to ~75% of the critical mass, and a multiplication of 100 to ~97-1/2% of critical. Where these values of multiplication or the fractions of critical mass appear as general safety criteria, reactivity limits equivalent to those for spherical fast neutron systems are implied.

In the region between delayed critical and prompt critical, the convenient safety index is the period of exponential rise of neutron level (i.e., the "positive period"). From the known relationship between positive period and reactivity level (as  $\Delta k$  in cents above delayed critical) for several fissionable materials, as determined by Keepin and Wimett<sup>(4, 5)</sup>, the margin from prompt critical is established for any measured period.

Simple rules stated in terms of the safety indices can define safe ranges for various normal types of operation. The regulations, as formulated, are not intended to cover all conceivable aspects of an inherently flexible program, and, for circumstances outside their

scope, the "Experimental Plan" serves as the vehicle for authorization of special operations.

In practice, it must be recognized that errors in interpretation of measurements, or malfunctioning of assembly machines, can offset the value of these regulations. This possibility can be minimized by requiring that observations be evaluated for consistency with knowledge that has been accumulated on similar systems. This requirement, of course, places great dependence upon the experience of personnel. As stated before, regulations alone cannot guarantee safety, but must be supplemented by the vigilance of the individuals performing each experiment.

#### I-D Nuclear Safety Committee

An "N-2 Nuclear Safety Committee," appointed by the Group Leader, shall serve in an advisory capacity with regard to any matter which concerns the nuclear safety of an operation. In addition to reviewing each experimental plan, this committee, on its own initiative, will scrutinize the safety of current practice as well as consider any complaint or suggestion from any member of the group.

#### II-A Definitions of Safety Plans 1, 2, and 3

The three Safety Plans 1, 2, and 3, for Kiva operation shall be retained but with new meanings. The 3-position selector switch will be a locked-type switch

and the positions cannot be changed without the use of the key, which shall be called the "Control Key." Only one such "Control Key" shall be in use, and all duplicate keys shall be locked in the Group Leaders' files. All three control rooms shall have similar switches but different keys. The redefined meanings of the plans are as follows:

Plan 1

This plan shall be used when the Kiva is not in use or when work that requires no power on any machine is proceeding in the Kiva. Under this plan:

1. There is no power on any machine.
2. The gates are open. (If closed, the gates will automatically open on change to Plan 1.)
3. The red warning blinker and rotating beacon lights are off. (Special lights such as those on Hydro may be on.)
4. The Security Inspectors are free to lock the Kiva doors according to their regular schedule, if it is obvious that no group is working in the Kiva. (Special instructions apply if the lights on Hydro or other special machines are blinking.)
5. A green panel light, illuminating a "1," shall be visible in the control room.

## Plan 2

This plan indicates preparation for operating a machine by remote control, the control of access to a Kiva area after machine operation, or "local operation" of a machine in the Kiva area. Under this plan:

1. No power is applied directly to a machine, and hence no machine can be operated from the control room. Power can be applied to those machines equipped with "Local Controls" by use of the "Control Key" in the lock switch on the "Local Controls" panel located in the Kiva.
2. The gates can be closed at the gate by a push button, and can be opened at the gate by the "Control Key."
3. The red warning blinker lights at the gates are on. The rotating beacon lights (located at the gate and in the Kiva area) are off.
4. An amber panel light, illuminating a "2," shall be visible in the control room.

## Plan 3

This plan is for remote operation of a machine in the Kiva. The "Control Key" cannot be removed while the switch is in this position. Under this plan:

1. Power is applied to the desired machine through a "Machine Selector" switch after the "Plan Selector" switch is in Plan 3 position. This permits the machine to be operated remotely from the control room, but it cannot be operated from the local control board in the Kiva. The purpose of the machine selector switch is to prevent operation of more than one machine at a time in a given Kiva.

2. The gates are closed by a push button at the gate, but cannot be opened at the gate since the "Control Key" cannot be removed from the Plan Selector lock while in the Plan 3 position. The gates shall be interlocked with the "scram" system, so that the machines cannot be reset unless the gates are closed.

3. The red blinker lights at the gate, and the rotating beacon lights at the gate and in the Kiva area, are "on" in the Plan 3 position. The warning horns are turned on for 5-10 seconds whenever the plan selector switch is turned to the Plan 3 position.

4. A red panel light, illuminating a "3," shall be visible in the control room.

## II-B Storage of Active Materials

Usually each Kiva will contain some active material

which is not involved in the experiment at hand and is not installed in another machine. In order to reduce the danger of a criticality accident with such material, a lockable area is provided in each Kiva exclusively for storage of fissionable material. Moderating materials, in particular, will be excluded from this area. Shelf spacings with allowed limits of active material per cubicle are chosen to be consistent with the regulations for storage given in TID-7016, Revision I, and in reference (6). For example, special metal clips conveniently limit the quantity of thin Oy foil per storage cubicle. Storage shelves in the vault have also been divided into standard-volume cubicles with an allowable limit in kilograms per cubicle, the limit depending upon the kind of material. The N-2 representative in charge of special materials has the responsibility for checking the Kivas and vault to see that the storage regulations, including those detailed in experimental plans, are followed in practice.

#### II-C Organization Regulations

1. Each new experiment involving active material must be reviewed by the Group Leader of N-2. Unless it is established that the quantity of active material

cannot be greater than three-fourths of a critical mass under foreseeable conditions, the experiment shall be covered by an "Experimental Plan" which shall be approved by the Chairman of the N-2 Safety Committee, by the Group Leader of N-2, and by the N-Division Leader.

2. Each experiment requiring an Experimental Plan shall be performed at one of the remote control laboratories (Kivas).

3. Each operating crew that performs the experiments shall be appointed by the Group Leader, and shall consist of a crew chief who is experienced in Pajarito methods of operation and at least one other competent person. The chief shall be responsible for all aspects of the crew's operation and shall regard personnel safety to be of paramount importance. If any crew member is dissatisfied with the safety of procedures, the operations shall be halted until all are convinced that the operations can be continued without risk.

4. Entrance to a Kiva for any operation on an assembly of active material shall be made by at least two persons, one of whom is the crew chief. If a person is required in the control room at the same time, a third person shall be assigned to the crew.



## II-D Equipment Regulations

1. Radiation and counting equipment to be used at each Kiva assembly shall include:

a. At least two long-geometry neutron counters (or their equivalent), one with an audible register. Scalers shall be available in both the Kiva and the control room.

b. An ionization chamber with a linear amplifier (or an equivalent system) for automatically recording in the control room the neutron flux level in the Kiva.

c. At least two "radiation monitors" or "scram monitors" for automatic disassembly of any remotely controlled machine at the desired preset neutron flux level. Normally, three such units shall be used.

d. Portable radiation survey meters (both neutron and gamma) shall be available.

1)  $\gamma$  and  $\alpha$  in each Kiva

2)  $\gamma$ , n, and  $\alpha$  in the control room area

2. All remote assembly machines and controls shall be designed so that equipment or power failure shall result in a safe configuration. Control switches for assembly mechanisms shall be of the "dead-man" type. Since the design specifications will vary with the amount of reactivity involved in a

particular type of experiment it will be convenient to classify the machines into three types according to the limit of operation.

Class I - Limit of Operation to be a Multiplication of  $\sim 100$  This group of machines must have:

a. At least one major disassembly mechanism which can be triggered (or scrambled) manually, and automatically by the radiation monitors. The disassembly process shall produce a monotonically decreasing reactivity at a rate which exceeds that of assembly, and shall result in a configuration with a multiplication ( $M$ ) less than 10. Assembly steps shall be interlocked as described below so that a definite sequence must be followed. Assembly rates shall be limited so that the rate of decrease of reciprocal multiplication cannot exceed .005 unit per second when the multiplication is greater than 10. Figure 14 shows some representative values of  $1/M$  plotted against the width of a central gap for several different assemblies taken at random. These values, normalized to close at  $1/M = .01$ , do not all represent "central source" multiplications, but they may be helpful in establishing rates

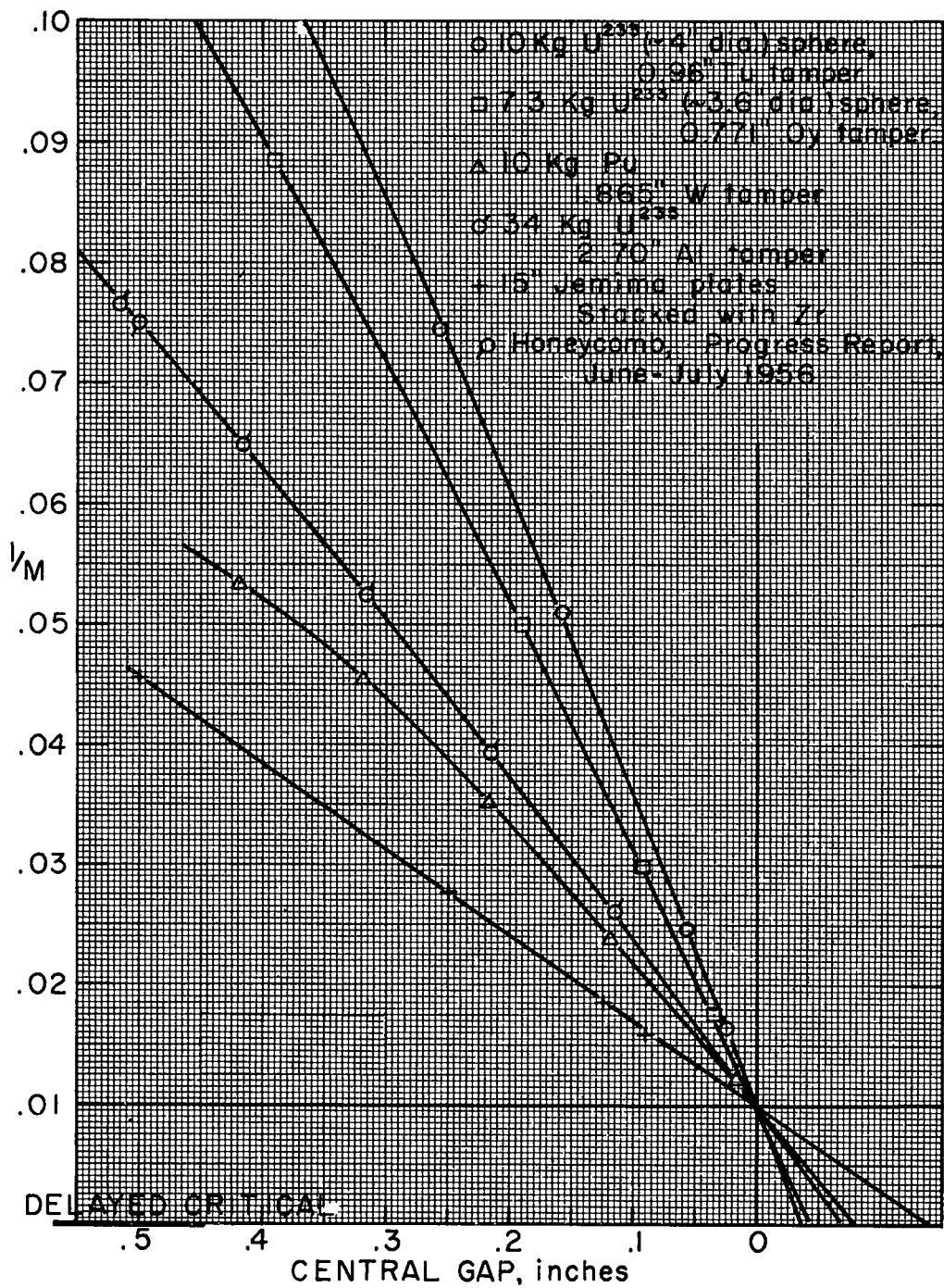

Figure 14. Dependence of reciprocal multiplication upon width of central gap in various assemblies.

of travel of rams used in assembling major pieces of active material.

b. Adjustable positive stops so that the multiplication may be measured as a function of closure distance if only large increments of material are available.

c. Indicators in the control room to give the position of the major movable part that completes the assembly.

Class II - Delayed Critical with Limit of Reactivity Corresponding to a Positive Period not Shorter than ~10 Seconds This type of machine must have:

a. At least two major disassembly mechanisms (of which one may be a set of safety rods) both of which can be triggered manually, or automatically by the radiation monitors. The disassembly process shall produce a decreasing reactivity at a rate which exceeds that of assembly, and shall result in a configuration with a multiplication of less than 10. At least one of the devices shall reduce the reactivity 100 cents or more in 1 second. The position of the major component that completes the assembly shall be shown by an indicator in the control room except on those machines, such

as Jezebel, in which excess reactivity is restricted in that the major components are not subject to change. Assembly rate of the major parts shall be limited so that reactivity cannot be added more rapidly than 5 cents per second when the multiplication is greater than 100.

b. One or more vernier control rods which will permit the reactivity to be changed in a continuous manner. Their overall value should be 50 cents or more. Their rate of travel shall be limited so that the reactivity cannot increase more than 5 cents per second. The position of the control rods shall be given at all times by indicators in the control room. The control rods shall be interlocked as described in a later paragraph.

Class III - This group will include machines intended for special purposes, such as Godiva II which was designed as a pulsed neutron source. In general they must include the basic design features of Class II but careful consideration in the Experimental Plan must be given to their special use.

3. Systems of interlocks and sequence of operation from the control room:

a. To reset the machine for operation, as indicated by a light on the control panel, the following conditions must be met to satisfy the interlocks in the scram circuit:

a-1. In the Kiva

a-1.1 Air pressure must be on if air cylinders are used for operation of the safety rods or disassembly mechanism. The "scram" system shall be interlocked so that the machine will scram and cannot be reset if the air pressure drops below some specified value.

a-1.2 A "scram button," interlocked with all machines in the Kiva and equipped with a reset, shall be located near the personnel door of each Kiva.

a-2. In the Control Room

a-2.1 Plan selector switch must be set on Plan 3 in order to apply power to the desired machine. In this position the gates are interlocked with the scram circuit and must be closed to reset the machine.

a-2.2 Linear amplifier must be on.

a-2.3 Scram monitors must be on and reset.

a-2.4 The machine must be disassembled to position of minimum reactivity, as indicated by an

appropriate light or lights.

a-2.5 "Control rods," if provided, must be in positions of minimum reactivity as indicated by appropriate lights.

a-2.6 "Safety rods," if provided, must be in positions of minimum reactivity, as indicated by appropriate lights.

b. Operation of the machine, after being reset, must proceed in the following sequence as provided by interlocks.

b-1. "Safety rods," if provided, must be moved to position of maximum reactivity which will be indicated by appropriate lights.

b-2. Power is now applied through proper interlocks so that the machine can be assembled. After complete assembly of the major parts to a maximum reactivity as indicated by a red limit light, the "control rod," if provided, can be moved to bring the reactivity to the desired level. If the major disassembly mechanism or the

safety rods are moved so as to open the limit switch, the machine must be reset before further use.

b-3. The machine will disassemble, either when a scram button is pushed, or by a signal from the scram monitors.

b-4. For "Local Operation" on Plan 2, all interlocks shall be identical to those on Plan 3 except that the "gates scram interlock" shall be by-passed.

b-5. On Plan 2, all limit lights shall indicate the proper position of all movable parts, but all control switches shall be locked out and inactive.

4. New machines:

a. Plans for the design of new machines shall be discussed with the N-2 Nuclear Safety Committee before construction of the machine. More general discussions within the group are also encouraged.

b. Reliability of operation of each new system shall be established by a series of successful dry runs before any active material is used, in order to insure proper behavior of the interlocks, scrams, etc.



## II-E Operating Procedure

1. Preparation for operation:
  - a. Neutron sources - Standard procedure requires the use of a neutron source in all assemblies for both local and remote operation. Exceptions to this rule must be specified in the Experimental Plan. Source strength and neutron counting equipment and techniques normally should be interrelated to give multiplication values within a statistical precision of  $\pm 5\%$ . In the case of Pu, the normal spontaneous-fission source is frequently adequate.
  - b. During operation periods, Plan 2, 3, entrance to the Kiva area shall be controlled by the crew chief. The "Control Key," (which shall be locked in the control room safe during non-operating periods) must be used to change the "Plan Selector Switch" to Plan 2 for "Local Operation" at the Kiva, or to Plan 3 for "Remote Operation" at the control room. A crew member must be in the control room at all times when on Plan 3, and if the control room area is to be vacated on Plan 2, the key must remain in the possession of a crew member or be locked in the safe.

c. Before operation, the Kiva area shall be cleared of personnel and the gates closed (selector switch on Plan 2 or 3). Tests shall be made to assure proper performance of the safety monitor systems (at least two independent monitors shall be functioning properly, although three shall normally be used) and of the manually actuated scrams. Since the level at which these monitors will trip is adjustable, the crew chief is responsible for setting them to respond to the lowest level consistent with the power at which the machine will be operated. The rotating beacon lights and the warning audio signal, which come on when power is applied to a machine on Plan 3, can be checked with the test button in the Kiva.

2. Local operation:

a. No assembly step may proceed in the presence of personnel unless there is clear evidence that the multiplication will not exceed 10. This may be inferred for any assembly that is clearly covered by the Nuclear Safety Guide, TID-7016 Rev. 1. Where such coverage is uncertain, multiplications must be measured and interpreted consistently with Sec IC, "Criteria for Regulations."

b. Any hand assembly of an unknown configuration shall be monitored by means of an audible counter responding to the influence of a neutron source within the system. Each step of reactivity increase shall be limited so that  $1/M$  is reduced by no more than a factor of two.

3. Remote operation - Class I machine:

a. Class I machines, which have no vernier control rods and no safety rods, have a limit of multiplication of  $\sim 100$ .

b. All assembly procedures shall be monitored by two or more counters which are sensitive to the influence of a neutron source placed in the system. If the "central source" multiplication is greater than 10, remote assembly from the control room must be used with the "scram monitors" and linear amplifiers connected into the "scram" circuit.

c. A plot of  $1/M$  vs the parameter controlling reactivity, such as the amount of active material, shall serve as a guide to the incremental increases in reactivity of an experimental assembly. In bringing the subunits (for a new configuration, or after any appreciable change in stacking) together for the first time by remote control, a

step-wise procedure shall be used for the first two points on such a  $1/M$  curve. This step-wise procedure shall consist of stopping the assembly at a known separation distance long enough to observe the response of the counters, the procedure being repeated as the separation distance is gradually decreased to zero, as long as the counters indicate such closure is safe. The above indicates a minimum requirement - more elaborate precautions shall be observed if closure is questionable. A plot of  $1/M$  for these first two points will then serve as a guide for adding the next increment of reactivity. Steps shall be limited so that  $1/M$  is reduced by no more than a factor of two at each step. If incremental amounts of material are large, a second plot of  $1/M$  against another variable, such as a step-wise variation in the distance between the two pieces, may be necessary to determine whether or not the second piece can be safely added. Some representative values of  $1/M$  vs width of a central gap are given in Figure 14.

d. Any major change in the stacking of active material or moderator shall be treated as a new assembly and must start with a stacking which is

known to be safe.

4. Remote operation - Class II machines:

a. Class II machines, which have appropriate safety devices and vernier reactivity control rods, and which are designed to operate at delayed critical, normally have a reactivity limit which corresponds to a positive period of  $\sim 10$  seconds. If reliability has been demonstrated at longer periods, and data at shorter periods are important, the positive periods may be decreased to  $\sim 5$  seconds by consent of the group leader. For periods shorter than 5 seconds, procedures and limits must be detailed in an experimental plan.

b. An initial approach to delayed critical shall be guided by a graph of  $1/M$  vs the parameter controlling reactivity, with step changes in reactivity limited so that  $1/M$  is reduced by no more than a factor of two in one step. This guide shall be followed until the reactivity is such that the control rod can be used to bring the assembly to delayed critical. Disassembly of the major parts shall result in a multiplication of 10 or less. Subsequent approaches to delayed critical, after the initial adjustment of reactivity has been made, should require only

the reassembly of the major parts and the use of the control rod, all of which can be done by remote control methods.

c. If an experiment requires step-wise changes in reactivity when the reactivity lies in the range of multiplication greater than 100 to delayed critical, such changes shall be less than 50 cents (or its equivalent value in  $\Delta(1/M)$ ), or less than the range of the vernier control rod. The equivalence between cents and  $\Delta(1/M)$  varies considerably for different types of assemblies. Some representative values are:

<u>Configuration</u>	<u>Machine</u>	<u><math>\Delta(1/M)/100\phi</math></u>	<u><math>\frac{\Delta m(\text{surface})}{m_c}/100\phi</math></u>
bare U <sup>235</sup>	Godiva	0.007	.0243
bare Pu <sup>239</sup>	Jezebel	0.002 <sub>5</sub>	.0069
bare U <sup>233</sup>	Jezebel	-	.0106
U <sup>235</sup> in thick U Topsy		0.009	.0242
Pu <sup>239</sup> in thickU Popsy		0.003	.010

d. For an unknown system progressing above delayed critical, measured positive periods and their relationship to reactivity in cents (relative to delayed critical), as given by Keepin and Wimett, serve as our best guide toward approaching shorter periods.

5. Remote operation - Class III machine: Since these machines are special cases of Class I or II, the initial approach to delayed critical and the determination of  $\Delta k$  for long positive periods shall normally be the same as 4 b, c, and d. Special operational features of this class of machine (such as Godiva bursts) and their limits of operation shall be detailed in their experimental plan.

6. Adjustments of machines during Plan 3: Occasionally it may be necessary for personnel to be in the Kiva while on Plan 3 in order to observe or to adjust the motion of a part such as a control rod, after the machine has initially been tested and placed in operation. Such operations are potentially dangerous, and shall be performed only by personnel thoroughly familiar with that particular machine, and only after taking definite precautions to insure that the multiplication cannot exceed 10. For example, such precautions might include the removal of active material, or the insertion of a mechanical stop that would prevent the assembly of the major units of active material.

#### II-F. Film Badges and Health Radiation Monitors

Regulations for radiation control appear in the H-1 booklet "Radiation Monitoring at Pajarito" and in LA-1835, the "Monitoring Handbook," but the following rules for

procedure should be specifically noted.

1. All persons entering the Kiva areas, or handling sources or any sizable amounts of active material, must wear standard film badges.
2. Neutron sources shall be swipe tested for leakage immediately before removal from or return to the source storage room. A health monitor shall be asked to investigate any evidence of leakage.
3. Before each day's operation with Pu or U<sup>233</sup>, enclosing surfaces shall be swipe tested, and any evidence of leakage shall be brought to the immediate attention of a health monitor.
4. Health monitors, stationed at Pajarito, will be available to give advice regarding radiation levels and tolerance doses. Their presence with the crew should be requested whenever there is significant risk of exposure. They should be notified of any change in crew schedule. They may require personnel to wear pocket dosimeters in addition to film badges if the radiation level is high.
5. In case of a radiation accident, plans for investigation at the Kiva areas must be made in cooperation with the health monitors.



## Accidents

A considerable amount of experimental and theoretical information is now available on the behavior of a variety of systems at high reactivities. LASL work<sup>(7)</sup> on Godiva through prompt critical predicts behavior of those fast neutron, metal systems where expansion due to heating is the primary mechanism for terminating an excursion. Borax<sup>(8)</sup>, Spert<sup>(9)</sup>, Kewb<sup>(10)</sup>, and Triga<sup>(11)</sup> are characteristic of solution or fluid systems where bubbling, boiling, and density change are the responsible quenching agents. Another class of system, whose behavior may be anomalous, consists of those in which active material is not closely coupled thermally to other materials of the core. An example is the U<sup>235</sup> foil loaded assembly with which this facility will be much concerned. Here there may be no major mechanism to stop the reaction until the fuel foils are vaporized.

In general, a highly supercritical system will react uncontrollably until the energy release is sufficient to overcome excess reactivity through: 1) overall effects which contribute promptly to negative temperature coefficient of reactivity such as expansion, change in neutron temperature, or doppler broadening; 2) perturbation of fuel geometry by boiling or gas evolution; or finally

3) mechanical disruption resulting in separation of components. It is assumed that scram mechanisms may play little part in limiting excursions at high reactivities. The amount of energy released will depend upon the amount of excess reactivity achieved and consequently, on the rate of adding reactivity. In the case of systems where spontaneous fission or  $\gamma$ -n processes do not result in significant neutron levels, it is possible to reach high excess reactivities without rapid assembly rates. (For this reason, no assembly is operated without an adequate neutron source.) Since mechanism 3) can overcome any quantity of excess reactivity, it is always the limiting case in an extreme accident where 1) and 2) are not sufficient to counteract the available excess reactivity. The situation may be very severe when the e-folding time of power becomes comparable to or less than the time required for materials to move significant distances at shock velocities. This catastrophic type of event should be extremely improbable with reasonable care in the design and operation of critical systems with respect to the limitation of available excess reactivity.

Since machinery and humans are fallible, it is unreasonable to ignore the possibility of a severe excursion, regardless of the probability. One is forced to consider the consequences of the limiting case where enough energy is generated to mechanically perturb the critical geometry. Accidental excursions that have occurred generally have been  $\sim 10^{17}$  fissions or less. It is justifiable to exclude from consideration accidents in large systems where the reaction is multiple or continues over a long period of time. Yields greater than  $10^{18}$  fissions have been obtained in these cases. In Borax I,  $3 \times 10^{18}$  fissions resulted in destruction of the reactor. Calculations at LASL<sup>(12)</sup> have predicted  $10^{19}$  fissions ( $\sim 0.1$  MW hr.) as the maximum accident in Kiwi-A resulting from suddenly filling the reactor with water. UCRL<sup>(13)</sup> has arrived at  $10^{19}$  fissions as a limiting excursion in a  $U^{235}$  foil graphite assembly where termination is accomplished by vaporization of the foils. It is assumed here that  $10^{19}$  fissions is an extreme upper limit for an accident.

As Kiva 3 wall shielding plus distance was designed to be at least as effective as isolation by 1/4 mile, and personnel are at that distance from the other operating Kivas, accident consequences will be discussed using this as the equivalent distance without shielding.

Measurements with Godiva show that  $10^{19}$  fissions from this type of system would give a total neutron and gamma dose of  $\sim 5$  rem at 1/4 mile. These data are from Kiva 2 where the building gives some attenuation, although it is of ordinary construction and not designed to provide shielding. (Calculations give  $\sim 7$  rem for fast neutrons alone from a point source of  $10^{19}$  fissions in air at 1/4 mile.) This example with an unreflected fast neutron assembly is more extreme than would be encountered with typical heavily reflected reactor systems.

More appropriate for judging contamination problems are the excellent data now available on gammas from fission products<sup>(14, 15)</sup>. (It is known that total energy is approximately equal for prompt and delayed gammas.) Figure 15 (from reference 14) shows the time distribution of delayed gamma energy from fission fragments. Integration of this curve for the first 1000 seconds gives the distribution in Table I for  $10^{19}$  fissions.

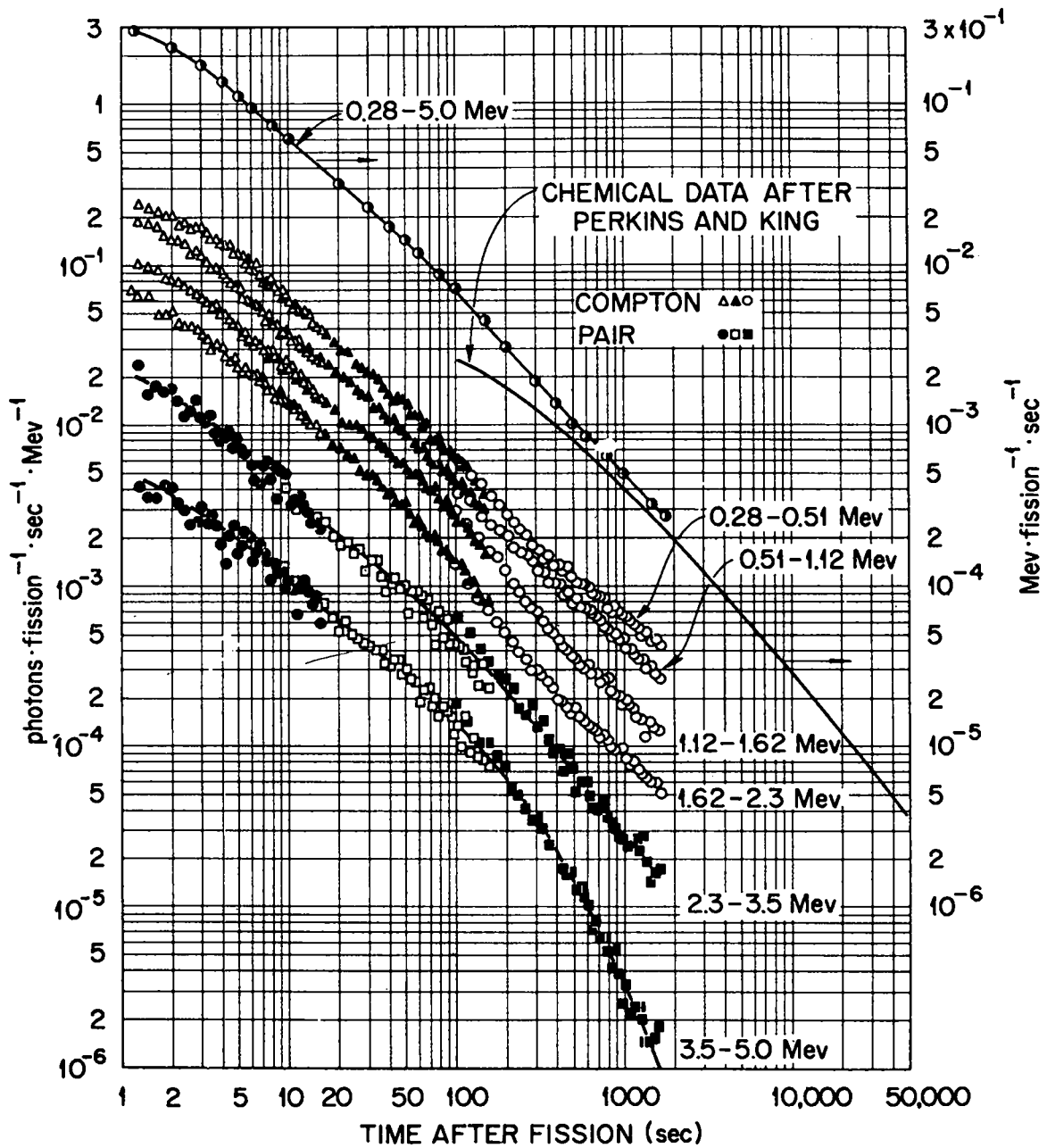

Figure 15. Time distribution of delayed gamma energy from fission fragments (from reference 14)

Table 1  
 Delayed Gamma Yield and Dose for  $10^{19}$  Fissions

<u>time, sec</u>	<u><math>\gamma</math>-energy increment in <math>10^{18}</math> mev</u>	<u>r at 1/4 mile</u>
0-1	3.0	0.024
1-2	2.5	0.020
2-5	4.8	0.039
5-10	4.0	0.033
10-20	4.5	0.037
20-50	6.0	0.049
50-100	5.0	0.041
100-1000	<u>12.6</u>	<u>0.102</u>
	42.4	0.345

Doses were computed using 400 yards as the attenuation distance and  $2 \times 10^9$  Mev/cm<sup>2</sup> for 1 r. Examination of Table I shows that 70% of the dose obtained in 1000 seconds occurs in the first 100 seconds. There is little additional contribution after 1000 seconds.

This simple point-source delayed-gamma-dose consideration is complicated by the possibility of air-borne contamination and fallout. Consequences of the latter have been estimated by computing the extreme case of all

fission fragments from a  $10^{19}$  fission excursion deposited uniformly over a 1/4 mile radius circle. The dose at the center of this circle 3 feet from the ground is  $\sim 11$  r for the first 1000 seconds. This number should be at least an order of magnitude higher than obtainable from any likely fallout pattern.

In the case of air-borne contamination, inhalation of fissionable material probably constitutes a greater hazard than inhalation of the short-lived fission products, especially in the case of  $U^{233}$  or Pu. Whereas, in the case of gamma and neutron dose from the prompt reaction and resultant fission fragments, isolation provides almost complete protection, there is a hazard from inhalation for an excursion which vaporizes fuel. The probability of high yield accidents with  $U^{233}$  or Pu, however, is very small. The spontaneous fission source present in Pu makes it impossible to reach high reactivities with slow assembly rates. Also, foil loadings, which may have no significant quenching mechanism other than vaporization, are not contemplated with these materials. Their inhalation hazard can be discounted only on the basis of probability.

### Hazard Evaluation

Normal operation of the Pajarito facility does not involve radiation levels that are hazardous to operating personnel or adjacent installations. No processes or operations are contemplated which might result in radioactive waste or the spread of contaminated material. Potential hazards are those associated with the accidental achievement of highly supercritical geometries and their resultant uncontrollable behavior. Two factors are major contributors to safety in the case of such radiation accidents: 1) the degree of isolation achieved by shielding and distance; and 2) the relatively small inventory of fission fragments as compared to research and power reactors.

In the previous section the most extreme cases have been considered. It was shown that accidents in which the energy liberated is sufficient to completely destroy an assembly result in relatively minor radiation exposures. Since most of the dose is accumulated in the first 100 seconds there is little basis for an elaborate disaster plan for evacuating the site rapidly. It is felt that in any credible radiation accident, distance from the main laboratory building adequately isolates personnel from consequences. Remoteness appears to give



adequate protection to other laboratory areas and private property. The arid nature of this region minimizes the chance of any local contamination reaching public water sources. (Note the acceptable location of contamination dumps in Figure 1.)

It is presented that the Pajarito facility, with safeguards provided by procedural control, does not constitute a significant hazard.

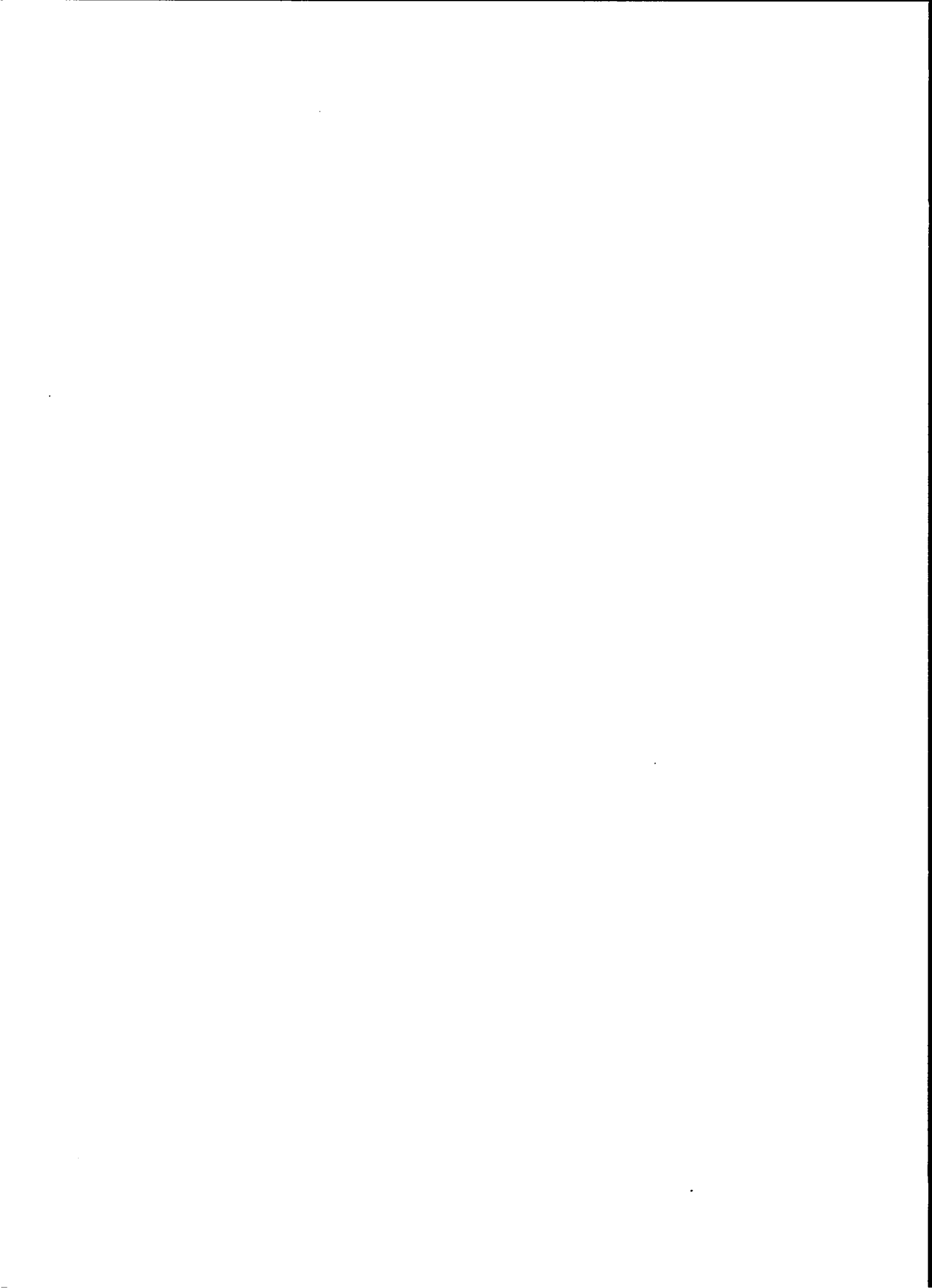

APPENDIX  
TYPICAL EXPERIMENTAL PLAN



## TYPICAL EXPERIMENTAL PLAN

Critical Mass Measurement of U-233, Pu-239, and a Composite  $\alpha$  Phase Pu-Oy Assembly in the Flat Top Thick Tu Geometry

Type of experiment: Delayed critical - remote control - no positive periods less than 10 seconds

Personnel: Chief - Safety

Assembly machine: Flat top

Starting date:

### Discussion of experiment

Material is now on hand for critical mass measurements of U-233  $\delta$ -phase Pu and a composite  $\alpha$  phase Pu-Oy system in the 19" OD Tu on Flat Top.

The following measurements are to be made:

- A. Critical mass
- B. Ratio of cross sections (25, 28, etc.) in the U-233 and  $\delta$ -Pu at various radii in core and tamper
- C. Foil activation (Au-In, etc.) in the U-233 -  $\delta$ -Pu at various radii
- D. Central mass radiochemistry  $(28)_{n\gamma}$   $(28)_{nf}$   $(28)_{n,2n}$  and perhaps others

#### E. Rossi- $\alpha$ (U-233-Pu)

While this material is available an attempt will be made to correlate the above information with previous measurements on other machines at Pajarito.

#### Description of assembly machine and materials

A. Assembly machine - Since a description of the assembly characteristics of Flat Top have not been reported in previous experimental plans a brief account is given here.

Figure A-1 is a schematic of the major components of the assembly machine. It consists of a 19" OD Tu tamper in a spherical geometry which will accommodate cores of fissionable material of various sizes. These cores "sit" on a cylindrical pedestal of Tu.

Tu shells of appropriate sizes are used to adapt the different sized spheres of fissionable material to the pedestal.

The tamper is divided into three main parts:

1. A stationary hemisphere which contains a 1" glory hole and three Tu control rods (E, F, and G). Rods F and G have a 6" stroke and E has a 4-1/4" stroke. Read-out of position to hundredths of an inch is available at the control room. Rod F is twice the

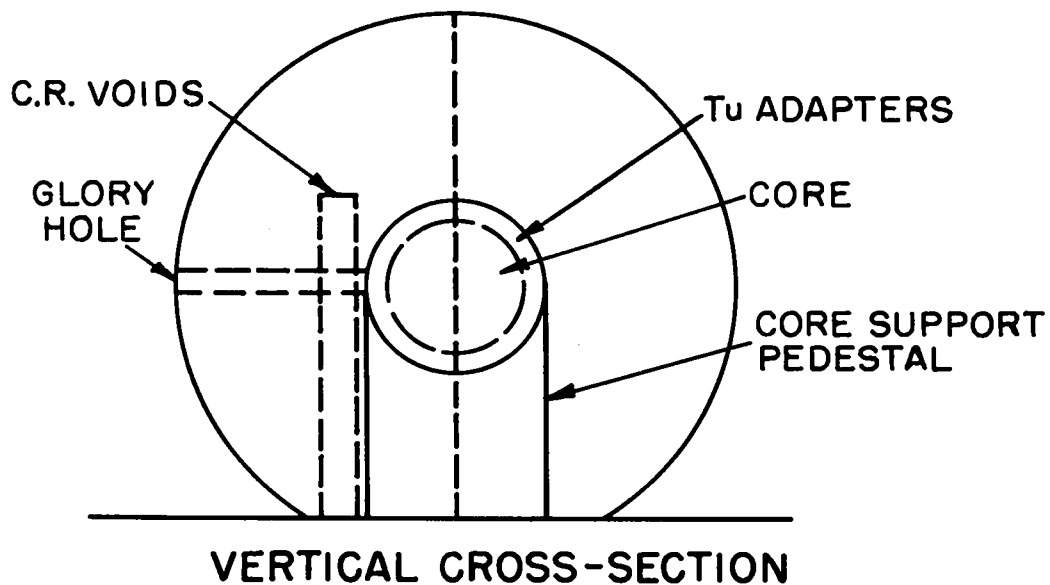
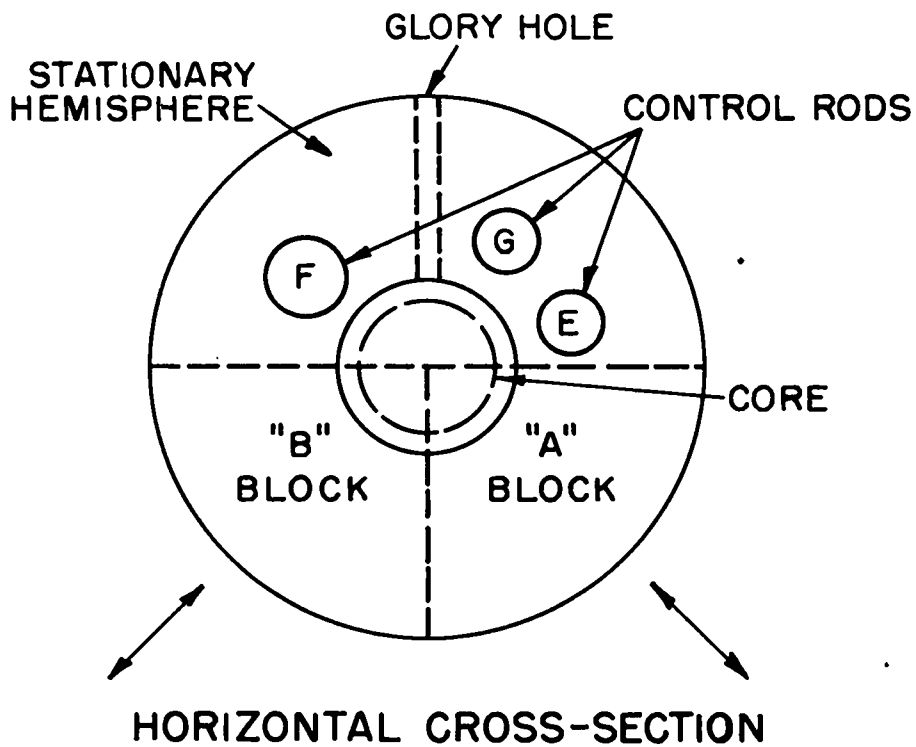

Figure A-1. Flat top schematic

diameter of the other two. Rod F is worth about 20¢/in. and E and G about 5¢/in. They require about one minute to travel full displacement.

2. Safety Block "A" - There are two "safety blocks" on this machine. These are quarter spheres mounted on a radial track and hydraulically actuated. "A" moves only from full out to in or vice versa with no provision for intermediate positioning. It travels at 1/3 inch/sec and has a displacement of 6".
  3. Safety Block "B" - A quarter sphere, hydraulically operated, which may be positioned at any point on its traverse with read-out of position to tenths of an inch (6" stroke). This block runs in to the 3/4" point at one inch/3 sec rate and automatically slows down to one inch/15 sec.
- By careful adjustment, these components can be made to fit together with a crack of the order of 0.002". This spacing is very reproducible as long as the pedestal containing the fissionable material is not disturbed.



However, when it is necessary to change components on the pedestal, some care must be exercised to reproduce its position in the cavity of the stationary tamper element since the fit of the tamper components is affected by this adjustment.

Operational procedure:

1. Reset - The machine must be in the following condition to be reset;
  - a. Pedestal in central cavity
  - b. Rods "out"
  - c. Safety blocks "out"
2. Assembly - The following sequence must be observed;
  - a. Block A to "in"
  - b. Block B to "in"
  - c. At this time any or all of the control rods may be moved to any position
3. Disassembly
  - a. Auto-run out - This operation starts rods and "B" block out simultaneously. Upon "B" reaching "out" position, "A" block is then sequentially moved to its out position. This is the normal

method of disassembly and is preferred to the more violent method of "scramming" which can cause shifting of components in the glory hole.

b. Scram - Simultaneous withdrawal of both blocks and rod run out.

(1) "A" block - withdrawal rate of 8.3 in./sec for 1st inch.

(2) "B" block - withdrawal rate of 6.7 in./sec with graded slow down.

(3) Rods withdrawn at assembly rate (one inch/10 sec).

4. Power failure

a. "A" and "B" blocks "scram" due to pressure in the accumulator of the hydraulic supply line.

B. Materials - Figures A-2 and A-3 are sketches of the core materials for each assembly. Suitable glory hole pieces are available for positioning chambers and foils at 1/2" or 1/4" radial increments.

#### Procedure for approach to critical

Until the critical mass of the Pu and 233 is established, some care must be exercised in assembly due to the small mass increment between delayed and prompt critical (~20 gms center

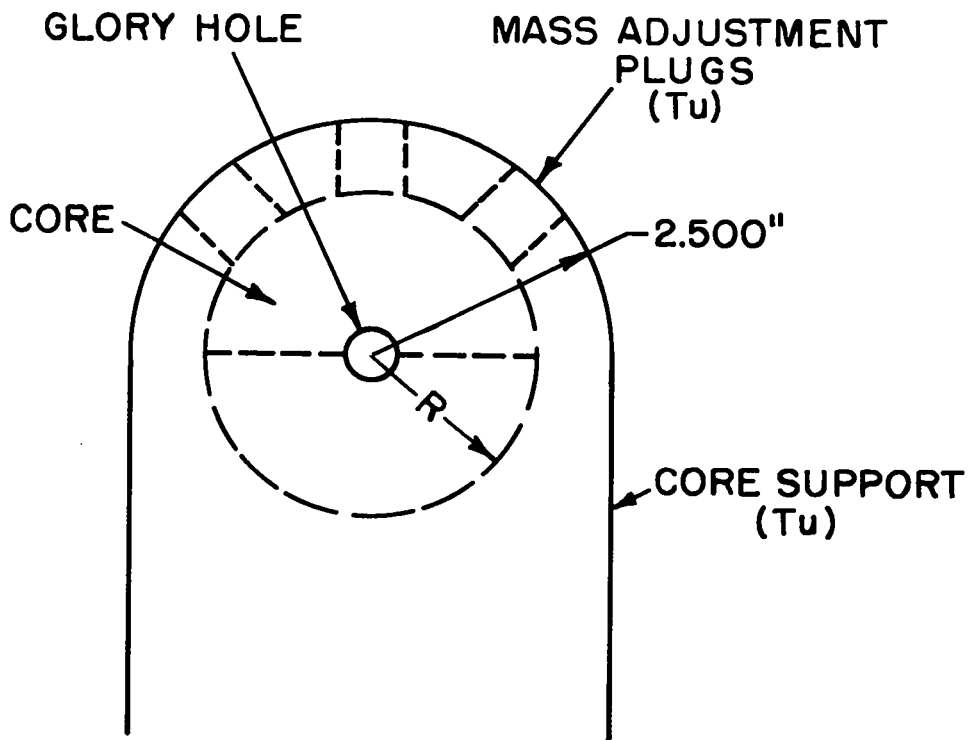

$R_{Pu} = 1.797''$  (COATED)  
 $R_{233} = 1.709''$  (COATED)  
 (0.005" Ni COAT ON Pu-233 PARTS)

Figure A-2. Pu - U-233 core assembly

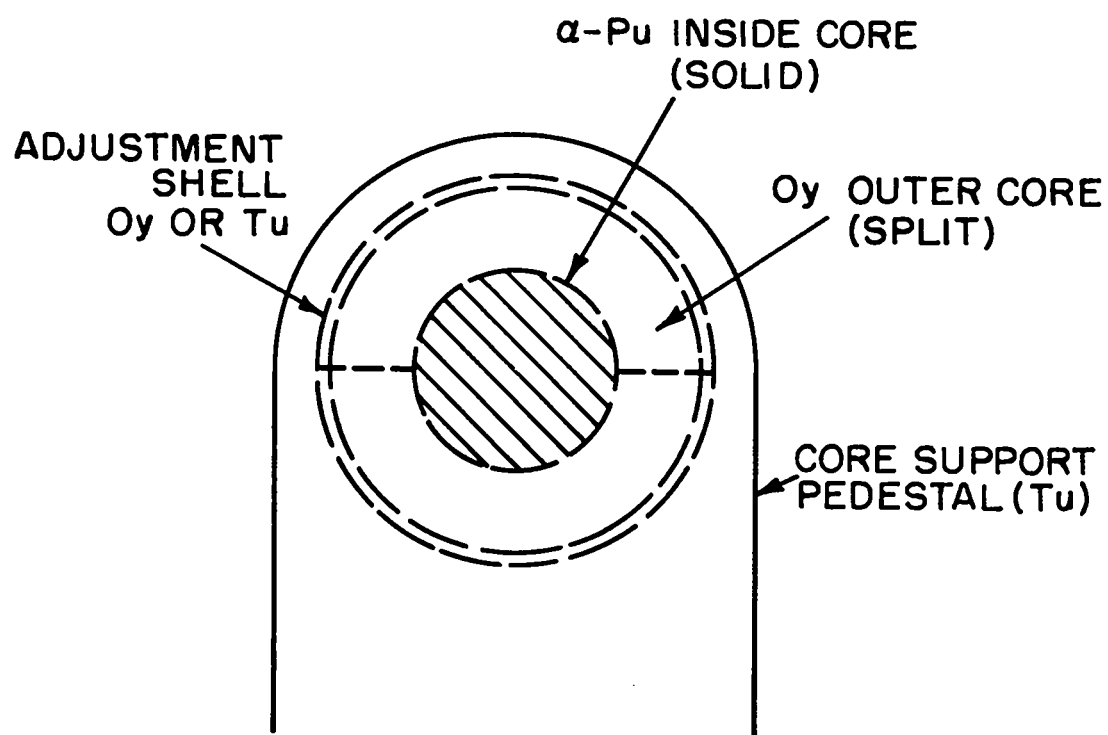

Figure A-3. Composite core

mass). Careful alignment of parts, and observation of assembly characteristics have been made to insure reproducibility of operations. Due to the high  $\gamma$  activity of the U-233, handling operations of this material must be minimized.

A. The following procedure will be observed for the U-233 and  $\delta$ -Pu assemblies:

1. Replace fissionable material with Al for an unmultiplied geometry with a Po-Be neutron source at the center of the assembly. Here Al is used rather than Tu because Tu parts were not available and the thick tamper did not require use of Tu.
2. A  $1/M$  vs mass curve will be plotted as each fissionable mass increment is added. Multiplication will be determined as the "B" block is closed. The effect of closing the last 1/2 inch will be controlled by means of positive stops, and the results appended to this experimental plan. A point for rods "out" and "in" will be taken to evaluate rod effectiveness with each mass addition.

B. For the composite  $\alpha$  phase Pu-Oy assembly.

1. Replace  $\alpha$ -Pu and thick Oy with Al. Thin Oy

shell with Tu.

2. Follow procedure of step 2 above.

### TYPICAL EXPERIMENTAL PLAN

Submitted by:

David M. Barton  
David M. Barton, N-2

Approved by:

Philip G. Koontz  
Philip G. Koontz, N-2  
Nuclear Safety Committee

John D. Orndoff  
John D. Orndoff  
Alt. Group Leader, N-2

R. E. Schreiber  
for R. E. Schreiber  
N-Division Leader

## REFERENCES AND FOOTNOTES

1. G. A. Jarvis, G. A. Linenberger, J. D. Orndoff, H. C. Paxton, "Two Plutonium-Metal Critical Assemblies," Nuclear Sci. and Eng. 8, 525-531 (1960).
2. F. F. Hart and E. C. Mallary, "Practical Aspects of Pajarito Neutron Multiplication Measurements," LA-1604, Sept. 1953.
3. For use as a safety criterion, neutron multiplication is obtained as follows. With a neutron source centered in the active material or its most reactive component, the multiplication is the ratio of long counter (or equivalent) response to the system with active material present to that with a mockup material (usually natural uranium or air) substituting for the active material.
4. G. R. Keepin and T. F. Wimett, "Reactor Kinetic Functions: A New Evaluation," Nucleonics, Vol. 16, Part 2, p. 86, Oct. 1958.
5. G. R. Keepin (in preparation), "Reactor Kinetics Handbook."
6. "Operating Manual for the Transfer and Storage of Special Nuclear Material," - Group ADP-SF.
7. G. E. Hansen, LASL Report LA-1441, "Burst Characteristics Associated with the Slow Assembly of Fissionable Materials," July 1952;  
T. F. Wimett, LASL Report LA-2029, "Time Behavior of Godiva through Prompt Critical," April 1957;  
W. R. Stratton, T. H. Colvin, R. B. Lazarus, Paper 431, 1958 Geneva Conference, "Analysis of Prompt Excursions in Simple Systems and Idealized Fast Reactors;"  
W. R. Stratton, Pergamon Press (1960), Progress in Nuclear Energy, Series IV, Vol. 3, p. 163-205, "A Review of Criticality Accidents."
8. J. R. Dietrich and D. C. Layman, Argonne National Laboratory Report, ANL-5211, "Transient and Steady State Characteristics of a Boiling Reactor;"  
J. R. Dietrich, Argonne National Laboratory Report, ANL-5323, "Experimental Investigation of the Self-

Limitation of Power During Reactivity Transients in  
a Subcooled, Water-Moderated Reactor."

9. W. E. Nyer and S. G. Forbes, Paper 2428, 1958 Geneva Conference, "Spert I Reactor Safety Studies."
10. M. E. Remley, et al, Paper 1079, 1958 Geneva Conference, "Experimental Studies on the Kinetic Behavior of Water Boiler Type Reactors."
11. Richard S. Stone, General Atomic Report, GA-721, "Triga Transient Experiments: Step Reactivity Insertions to 2 Dollars."
12. W. R. Stratton, "Summary: H<sub>2</sub>O Flooding of Core," Rough Draft N-2-1325.
13. O. Kolar, et al, Lawrence Radiation Laboratory Report, COVA-320, "Puppy Hazard Report."
14. Maienschein, Peele, Love, Zobel, UN Paper 670 (1958).
15. Bolles, Ballou, Nuclear Science and Engineering, 5, 156-185 (1959).